

P-13670

X1772

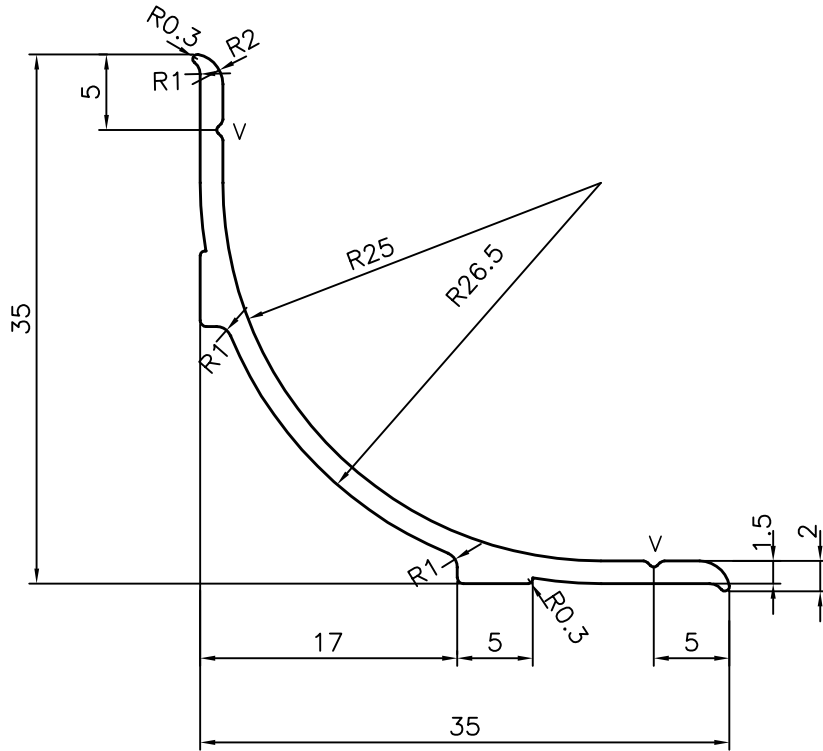

V =V GROOVE 0.4x90°(2 PLACES)

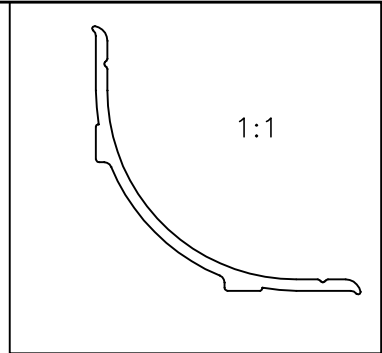

SYMBOL OF QUALITY
AN ISO 9001 COMPANY

JINDAL ALUMINIUM LTD.
BANGALORE-560073 (INDIA)

	NAME	DATE
DRAWN	J.P.KAUSHIK	20-06-2014
CHECKED		
APPROVED	J.N.RAI	05-07-2014
SCALE		2:1
AREA mm ²		94.597
PERIMETER mm.		120.8
WEIGHT kg/m		0.255
DRAWING No.	SECTION No.	
P-13670	-	
X1772	X1772	

1. ALL DIMENSIONS ARE IN mm.
2. ROUND OFF ALL SHARP CORNERS WITH 0.40 mm.
3. TOLERANCES WILL BE AS PER,BS:EN-755-9 UNLESS OTHERWISE SPECIFIED

PARTY'S NAME	ULLRICH ALUMINIUM, AUSTRALIA
PARTY'S DRAWING No.	164A5899
ALLOY & TEMPER	6060 T5
DESCRIPTION	MISC. SECTION