

P-14084

X1811

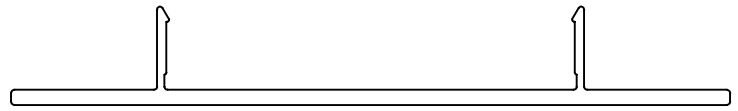

SCALE: - 1:1

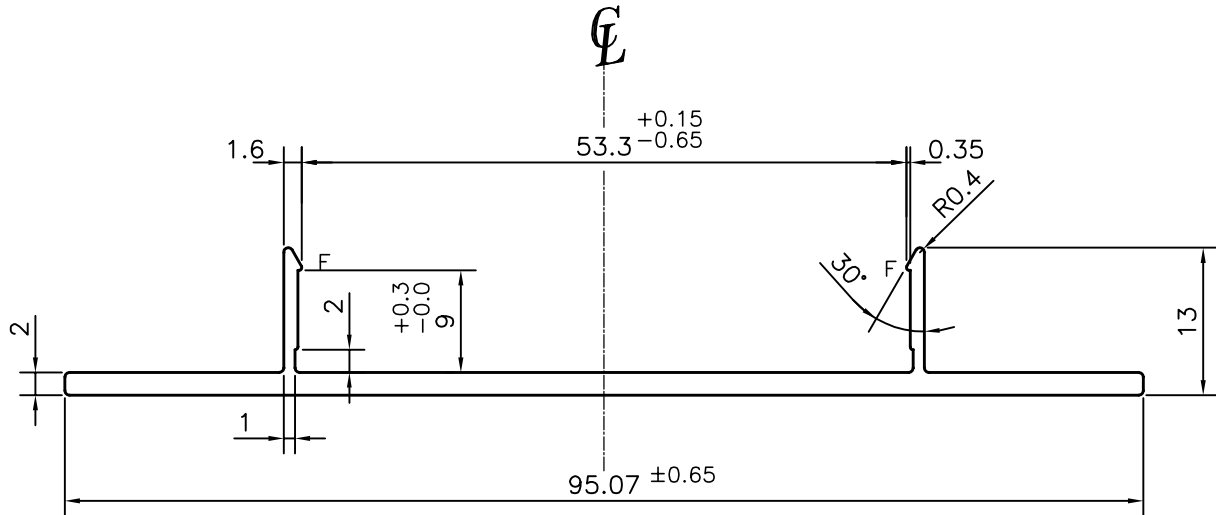

F = FULL RADIUS (2 PLACES)



SYMBOL OF QUALITY
AN ISO 9001 COMPANY

JINDAL ALUMINIUM LTD.
BANGALORE-560073 (INDIA)

	NAME	DATE
DRAWN	PARVESH	08-11-2014
CHECKED		
APPROVED	S.S.GARG	13-11-2014
SCALE		1.5:1
AREA mm ²		216.272
PERIMETER mm.		236.88
WEIGHT kg/m		0.584
DRAWING No.	SECTION No.	
P-14084	-	
X1811	X1811	

1. ALL DIMENSIONS ARE IN mm.
2. ROUND OFF ALL SHARP CORNERS WITH 0.40 mm.
3. TOLERANCES WILL BE AS PER BS:EN-755-9 , UNLESS OTHERWISE SPECIFIED

PARTY'S NAME SIGNET SIGN SYSTEM, SWEDEN

PARTY'S DRAWING No. 119339 (TC-95)

ALLOY & TEMPER 6063 T6

DESCRIPTION CLIP SECTION (END CAP)