

P-14055

X1819

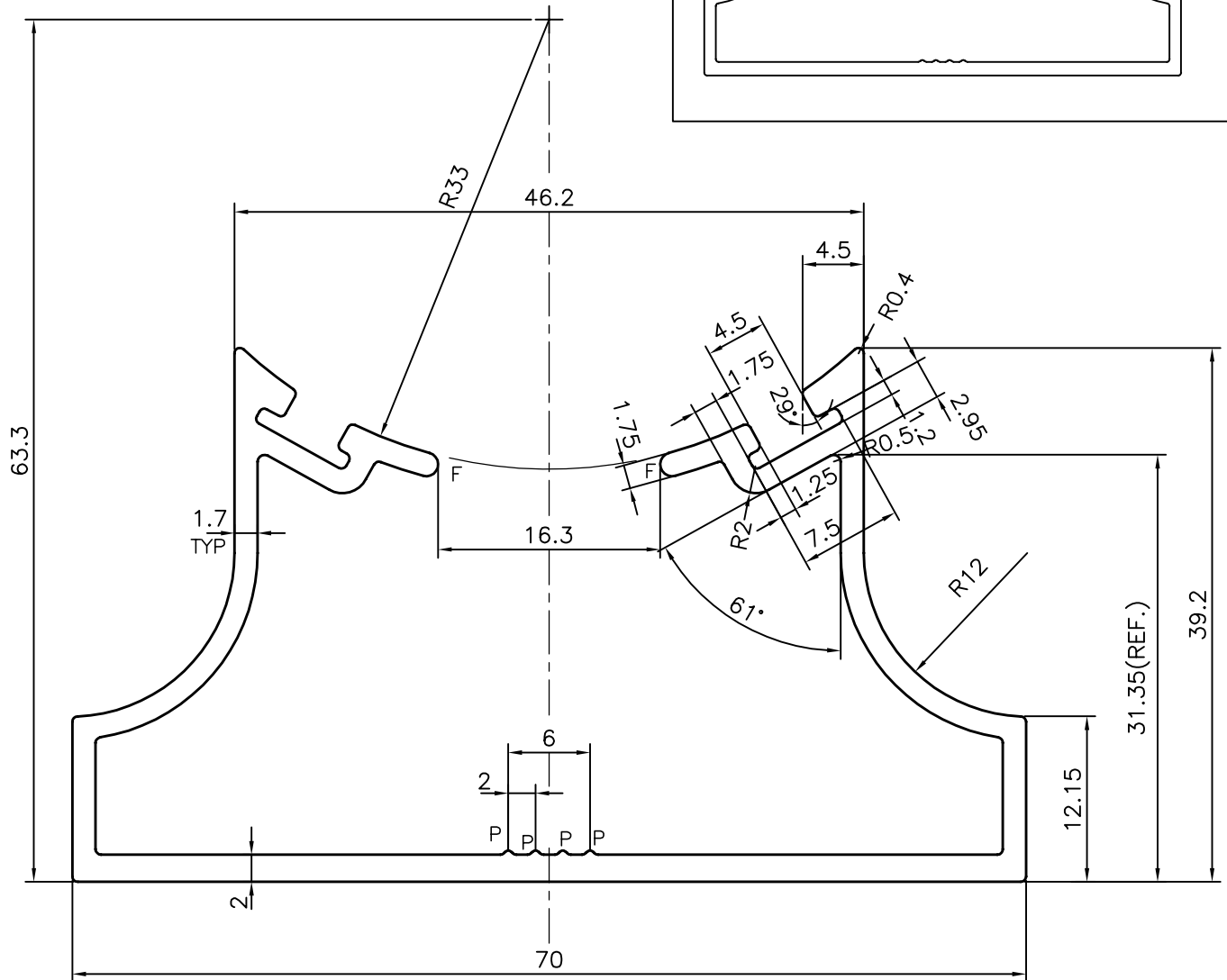

F = FULL RADIUS (2 PLACES)  
 P = PIP = 0.3x90°(4 PLACES)

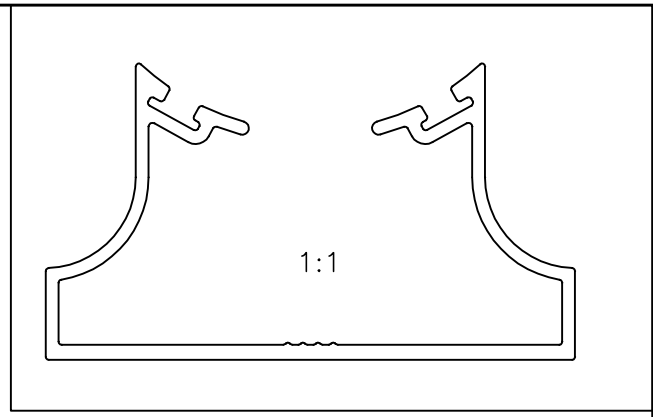

SYMBOL OF QUALITY  
 AN ISO 9001 COMPANY

**JINDAL ALUMINIUM LTD.**  
 BANGALORE-560073 (INDIA)

	NAME	DATE
DRAWN	J.P.KAUSHIK	20-10-2014
CHECKED		
APPROVED	S.S.CARG	29-11-2014

1. ALL DIMENSIONS ARE IN mm.
2. ROUND OFF ALL SHARP CORNERS WITH 0.40 mm.
3. TOLERANCES WILL BE AS PER BS:EN-755-9, UNLESS OTHERWISE SPECIFIED

SCALE	2:1
AREA mm <sup>2</sup>	361.548
PERIMETER mm.	387.528
WEIGHT kg/m	0.976

PARTY'S NAME	PD ALUMINIUM LTD., UK	DRAWING No.	P-14055	SECTION No.	-
PARTY'S DRAWING No.	AS PER SAMPLE(CS 43)		X1819		X1819
ALLOY & TEMPER	6063 T6				
DESCRIPTION	MISC. SECTION				