

P-14212

X1823

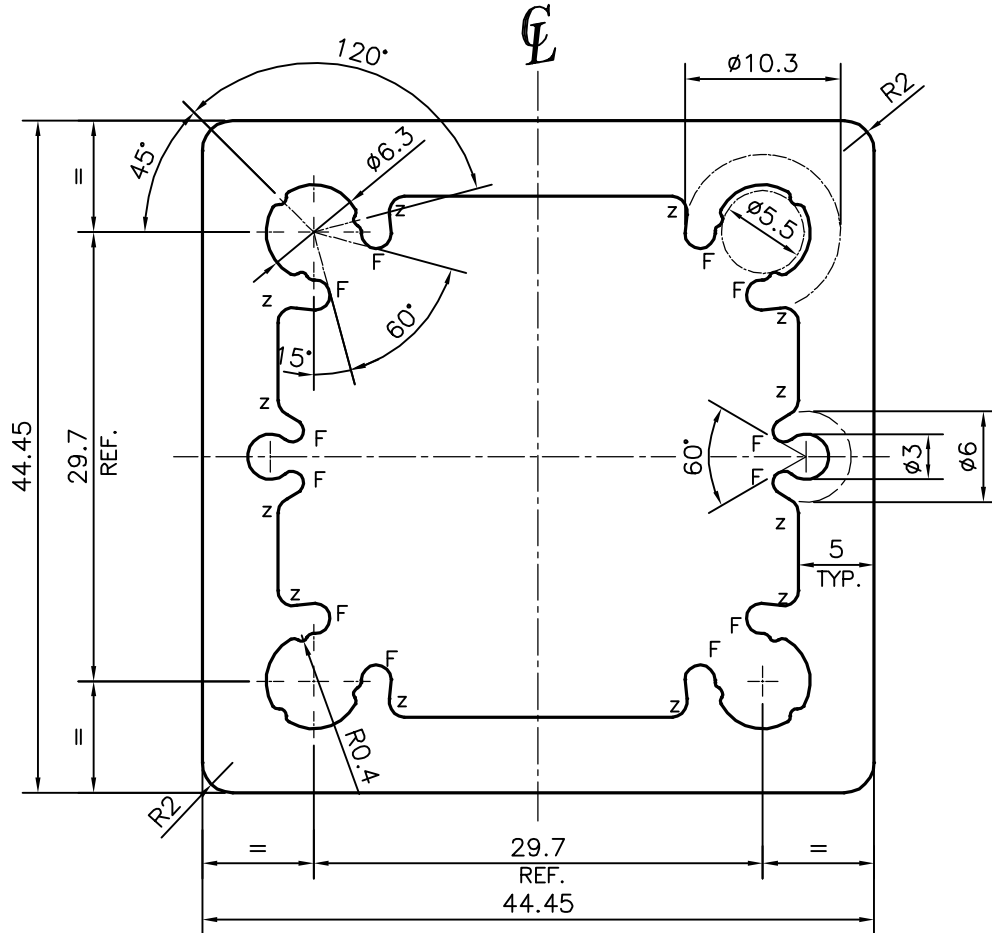

ISSUE-2

ALL SCREW BOX SIZE & SHAPE CHANGED

WEIGHT ALSO CHANGED FROM 2.259 TO 2.241 kg/m

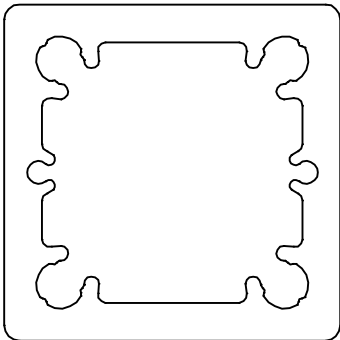

SCALE: - 1:1

F = FULL RADIUS (12 PLACES)  
Z = RADIUS 1 mm.(12 PLACES)

TOLERANCE CHART CD = CIRCUMSCRIBING CIRCLE

DIMENSION	CD≤100	100<CD≤200	200<CD≤300	300<CD≤500
UPTO 10mm	±0.25	±0.30	±0.35	±0.40
10.0 - 25.0	±0.30	±0.40	±0.50	±0.60
25.0 - 50.0	±0.50	±0.60	±0.80	±0.90
50.0 - 100	±0.70	±0.90	±1.10	±1.30
100 - 150	-	±1.10	±1.30	±1.50
150 - 200	-	±1.3	±1.50	±1.80
200 - 300	-	-	±1.70	±2.10
300 - 450	-	-	-	±2.80



SYMBOL OF QUALITY  
AN ISO 9001 COMPANY

**JINDAL ALUMINIUM LTD.**  
BANGALORE-560073 (INDIA)

	NAME	DATE
DRAWN	J.P.KAUSHIK	10-02-2018
CHECKED		
APPROVED	B.NATARAJA	16-09-2020

1. ALL DIMENSIONS ARE IN mm.
2. ROUND OFF ALL SHARP CORNERS WITH 0.40 mm.
3. TOLERANCES WILL BE AS PER BS:EN-755-9, UNLESS OTHERWISE SPECIFIED

SCALE	2:1
AREA mm <sup>2</sup>	829.835
PERIMETER mm.	174.366
WEIGHT kg/m	2.241

PARTY'S NAME	PROSOURCE INDL. SOLUTIONS INC., CANADA
PARTY'S DRAWING No.	AS PER AUTOCAD DRAWING
ALLOY & TEMPER	6005 T5
DESCRIPTION	HANDRAIL SECTION-RAILING

DRAWING No.	SECTION No.
P-14212	-
X1823	X1823(ISSUE-2)