

P-14368

X1827

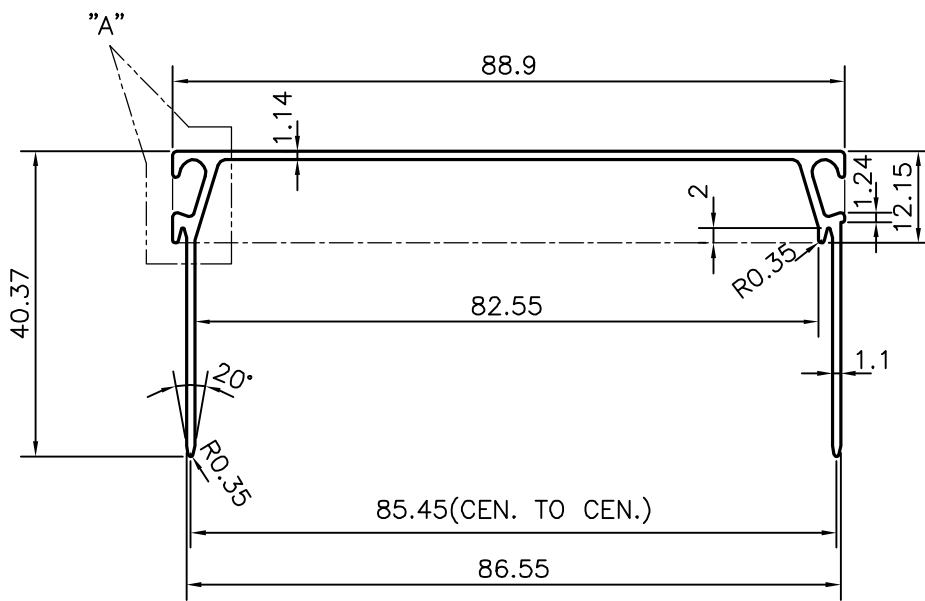
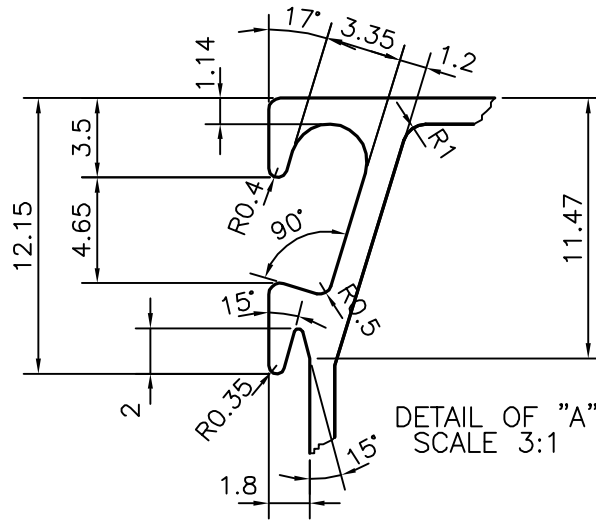

SYMBOL OF QUALITY
AN ISO 9001 COMPANY

JINDAL ALUMINIUM LTD.
BANGALORE-560073 (INDIA)

	NAME	DATE
DRAWN	J.P.KAUSHIK	21-01-2015
CHECKED		
APPROVED	S.S.GARG	23-01-2015

1. ALL DIMENSIONS ARE IN mm.
2. ROUND OFF ALL SHARP CORNERS WITH 0.40 mm.
3. TOLERANCES WILL BE AS PER BS:EN-755-9 , UNLESS OTHERWISE SPECIFIED

SCALE	1:1
AREA mm ²	210.025
PERIMETER mm.	355.908
WEIGHT kg/m	0.567

PARTY'S NAME WHITE ALUMINIUM PRODUCTS LLC, USA

DRAWING No. SECTION No.

PARTY'S DRAWING No. AS PER AUTOCAD DRAWING

P-14368 -
X1827 X1827

ALLOY & TEMPER 6063 T6

DESCRIPTION 3.5" AEROSPACE BEAM r2