

P-14320

X1829

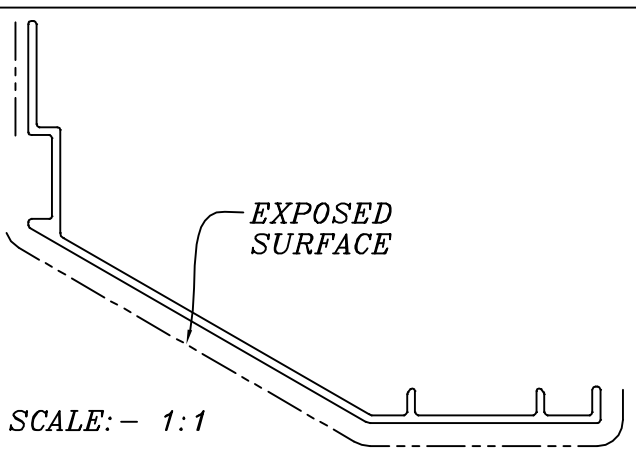
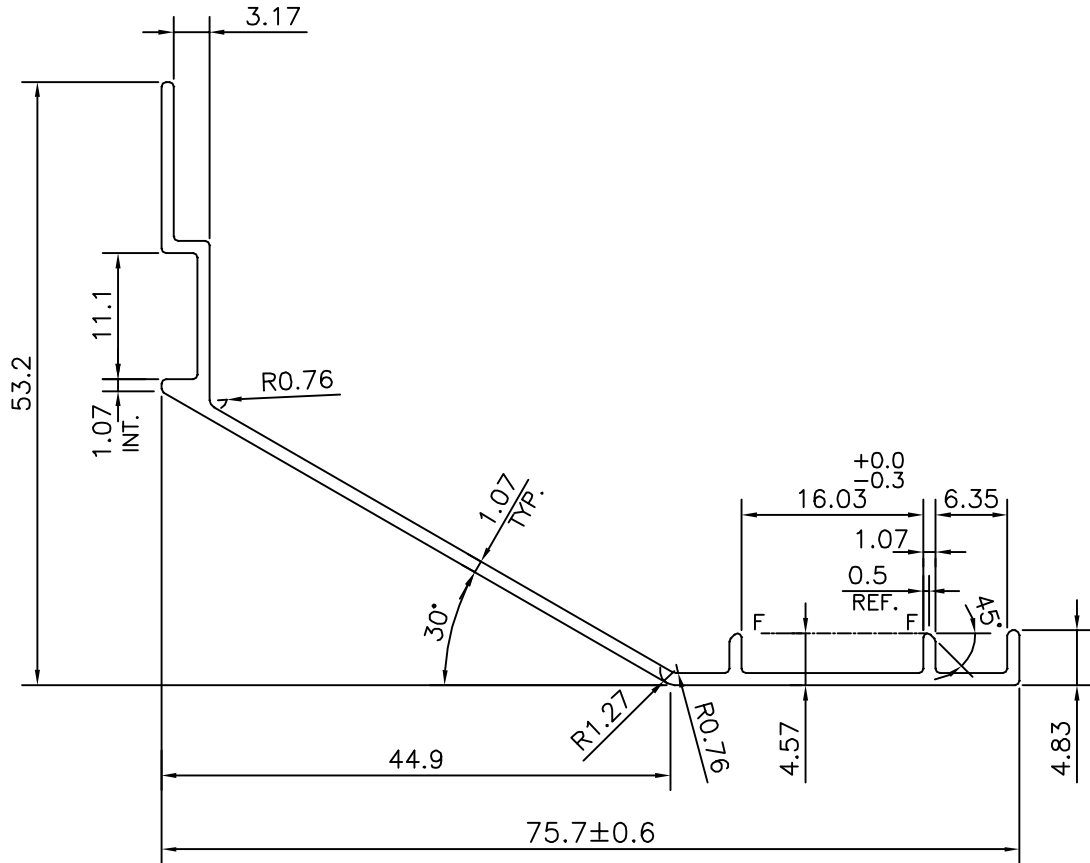

F = FULL RADIUS (2 PLACES)

TOLERANCE CHART CD = CIRCUMSCRIBING CIRCLE

DIMENSION	CD ≤ 100	100 < CD ≤ 200	200 < CD ≤ 300	300 < CD ≤ 500
UPTO 10mm	±0.25	±0.30	±0.35	±0.40
10.0 - 25.0	±0.30	±0.40	±0.50	±0.60
25.0 - 50.0	±0.50	±0.60	±0.80	±0.90
50.0 - 100	±0.70	±0.90	±1.10	±1.30
100 - 150	-	±1.10	±1.30	±1.50
150 - 200	-	±1.3	±1.50	±1.80
200 - 300	-	-	±1.70	±2.10
300 - 450	-	-	-	±2.80



SYMBOL OF QUALITY
AN ISO 9001 COMPANY

JINDAL ALUMINIUM LTD.
BANGALORE-560073 (INDIA)

	NAME	DATE
DRAWN	PARVESH	12-01-2015
CHECKED		
APPROVED	S.S.GARG	23-01-2015

1. ALL DIMENSIONS ARE IN mm.
2. ROUND OFF ALL SHARP CORNERS WITH 0.40 mm.
3. TOLERANCES WILL BE AS PER BS:EN-755-9 , UNLESS OTHERWISE SPECIFIED

SCALE	1.5:1
AREA mm ²	135.515
PERIMETER mm.	245.444
WEIGHT kg/m	0.366

PARTY'S NAME	BADAR AL MULLA & BROTHER'S CO. WLL., KUWAIT
PARTY'S DRAWING No.	1894
ALLOY & TEMPER	6060 T6
DESCRIPTION	AIR GRILL SECTION

DRAWING No.	SECTION No.
P-14320	-
X1829	X1829