

P-14461-2

X1859

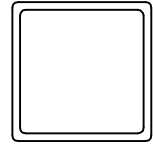

SCALE: - 1:1

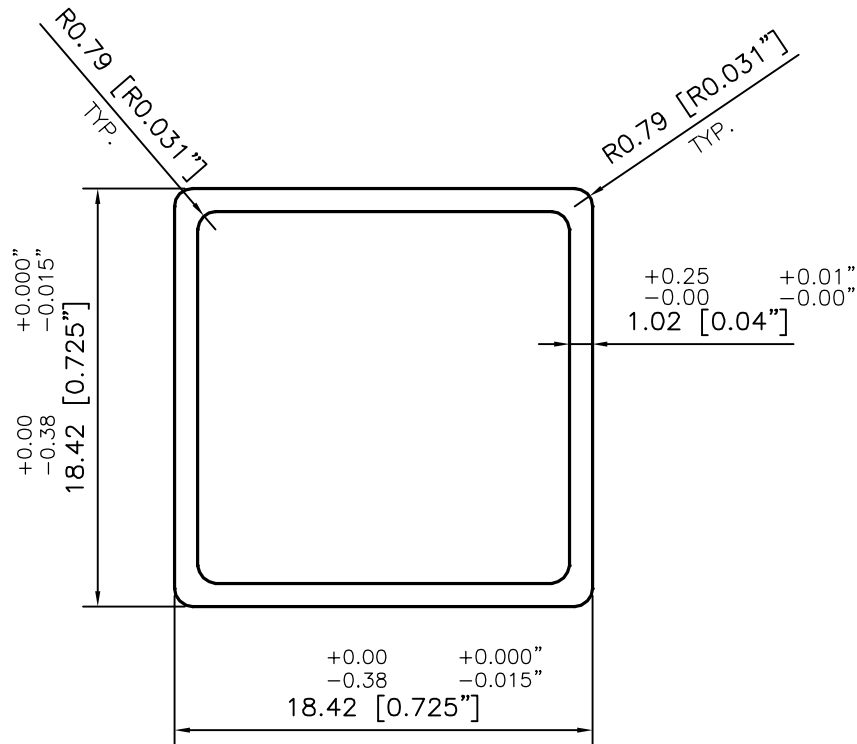

☞ AS PER DRAWING WEIGHT LIMIT WILL BE
0.185 TO 0.239 kg/m.

☞ FOR DISPATCH 114 TO 148 PIECES (AVERAGE) IN 100 kg.

1. STRAIGHTNESS=1.5 mm/M
2. TWIST=1.5 mm/M
3. ANGULARITY= $\pm 1.5^\circ$
4. FLATNESS =0.005xWIDTH
5. WEBSTER =7-9



SYMBOL OF QUALITY
AN ISO 9001 COMPANY

JINDAL ALUMINIUM LTD.
BANGALORE-560073 (INDIA)

	NAME	DATE
DRAWN	PARVESH	07-03-2015
CHECKED		
APPROVED	B.NATARAJA	16-03-2015
SCALE		3:1
AREA mm ²		70.992
PERIMETER mm.		72.324
WEIGHT kg/m		0.192
DRAWING No.	SECTION No.	
P-14461-2	-	
X1859	X1859	

1. ALL DIMENSIONS ARE IN mm.
2. ROUND OFF ALL SHARP CORNERS WITH 0.79 mm.
3. TOLERANCES WILL BE AS PER BS:EN-755-9 , UNLESS OTHERWISE SPECIFIED

PARTY'S NAME	SINOPEC RESOURCES LLC, USA
PARTY'S DRAWING No.	40106
ALLOY & TEMPER	6063 T52
DESCRIPTION	SQUARE TUBE WITH CORNER RADIUS