

P-14609-2

X1880

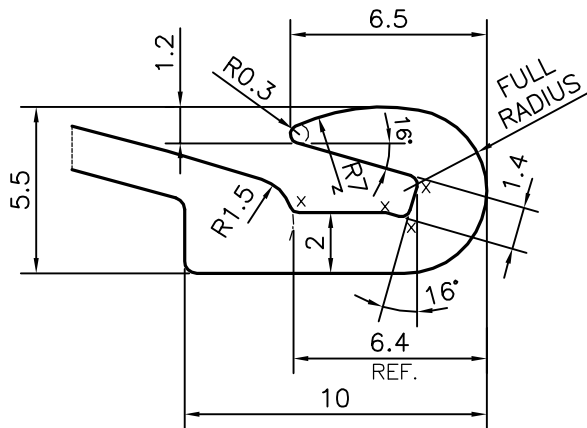

DETAIL OF "A"
SCALE 4:1

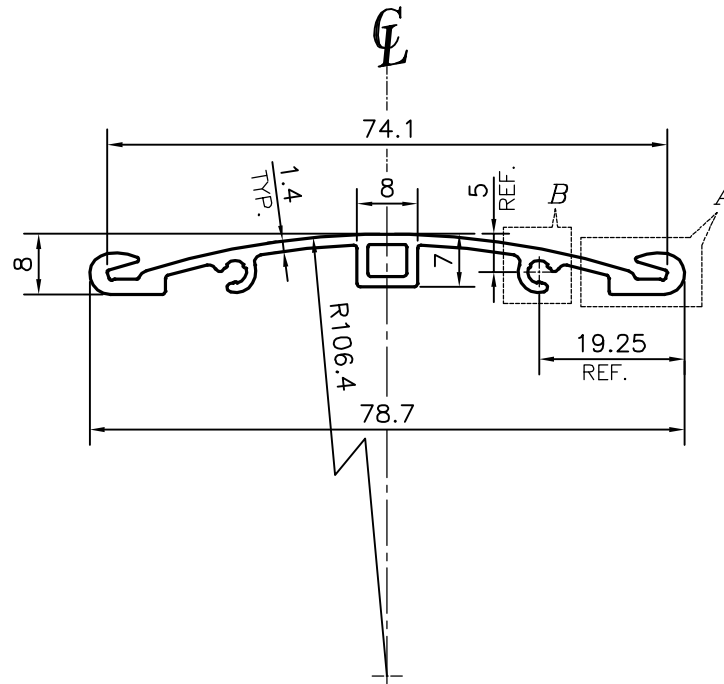
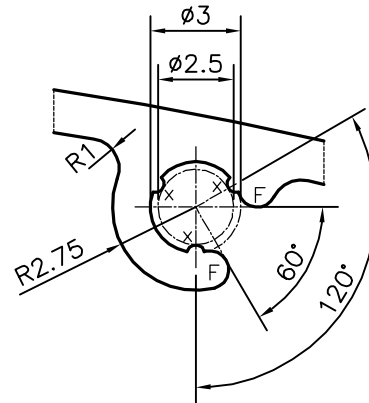

DETAIL OF "B"
SCALE 4:1

X = RADIUS 0.3 mm.(11 PLACES)
F = FULL RADIUS (2 PLACES)



SYMBOL OF QUALITY
AN ISO 9001 COMPANY

JINDAL ALUMINIUM LTD.
BANGALORE-560073 (INDIA)

	NAME	DATE
DRAWN	PARVESH	06-05-2015
CHECKED		
APPROVED	S.S.GARG	01-06-2015

1. ALL DIMENSIONS ARE IN mm.
2. ROUND OFF ALL SHARP CORNERS WITH 0.40 mm.
3. TOLERANCES WILL BE AS PER BS:EN-755-9 , UNLESS OTHERWISE SPECIFIED

SCALE	1:1
AREA mm ²	200.007
PERIMETER mm.	226.415
WEIGHT kg/m	0.540

PARTY'S NAME	SIGNET SIGN SYSTEM, SWEDEN	DRAWING No.	SECTION No.
PARTY'S DRAWING No.	AS PER SAMPLE & REQUIREMENT (C-7)	P-14609-2	-
ALLOY & TEMPER	6063 T6	X1880	X1880
DESCRIPTION	DISPLAY SECTION		