

P-14610-1

X1881

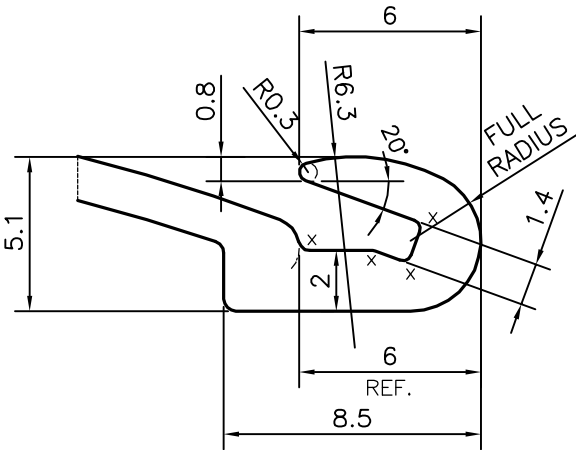

DETAIL OF "A"  
SCALE 4:1

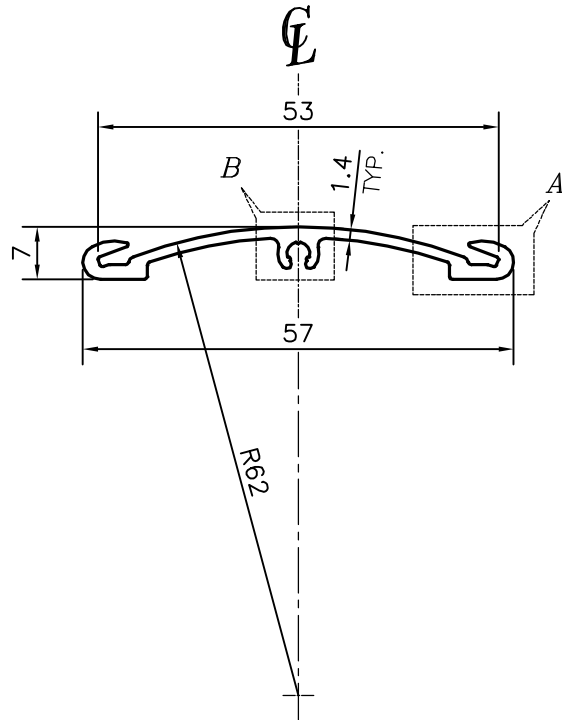
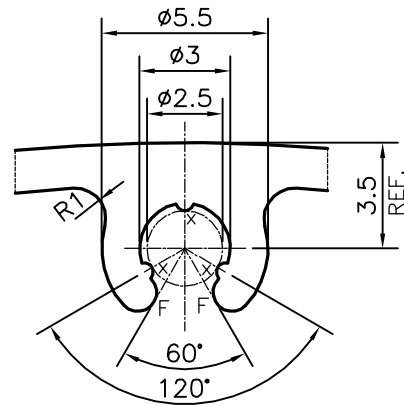

DETAIL OF "B"  
SCALE 4:1

X = RADIUS 0.3 mm.(11 PLACES)  
F = FULL RADIUS (2 PLACES)



SYMBOL OF QUALITY  
AN ISO 9001 COMPANY

**JINDAL ALUMINIUM LTD.**  
BANGALORE-560073 (INDIA)

	NAME	DATE
DRAWN	PARVESH	05-05-2015
CHECKED		
APPROVED	S.S.GARG	01-06-2015
SCALE		1:1
AREA mm <sup>2</sup>		126.894
PERIMETER mm.		158.651
WEIGHT kg/m		0.343
DRAWING No.	SECTION No.	
P-14610-1	-	
X1881	X1881	

1. ALL DIMENSIONS ARE IN mm.
2. ROUND OFF ALL SHARP CORNERS WITH 0.40 mm.
3. TOLERANCES WILL BE AS PER BS:EN-755-9, UNLESS OTHERWISE SPECIFIED

PARTY'S NAME	SIGNET SIGN SYSTEM, SWEDEN
PARTY'S DRAWING No.	AS PER SAMPLE (C-8)
ALLOY & TEMPER	6063 T6
DESCRIPTION	DISPLAY SECTION