

P-14883

X1898

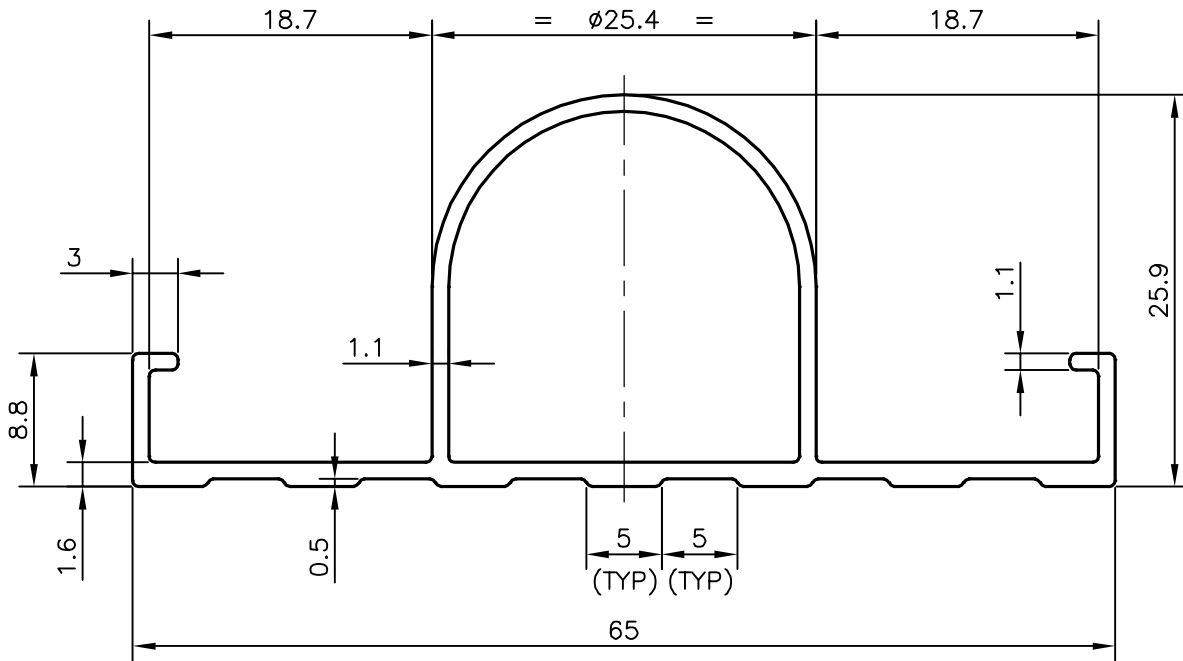
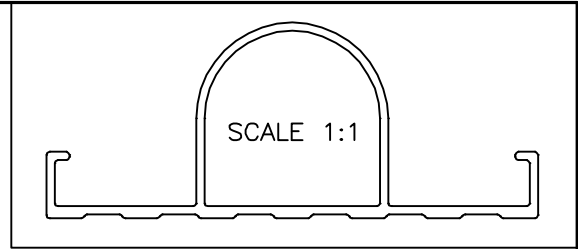

SYMBOL OF QUALITY  
AN ISO 9001 COMPANY

**JINDAL ALUMINIUM LTD.**  
BANGALORE-560073 (INDIA)

	NAME	DATE
DRAWN	J.P.KAUSHIK	15-07-2015
CHECKED		
APPROVED	B.NATARAJA	18-07-2015
SCALE		2:1
AREA mm <sup>2</sup>		176.352
PERIMETER mm.		207.385
WEIGHT kg/m		0.476
DRAWING No.	SECTION No.	
P-14883	-	
X1898	X1898	

1. ALL DIMENSIONS ARE IN mm.
2. ROUND OFF ALL SHARP CORNERS WITH 0.40 mm.
3. TOLERANCES WILL BE AS PER IS:6477-1983 UNLESS OTHERWISE SPECIFIED

PARTY'S NAME	SRK LADDERS, PUTTUR (DK)
PARTY'S DRAWING No.	LIGHTER OF SECTION No:-22566
ALLOY & TEMPER	HE9 WP
DESCRIPTION	LADDER SECTION