

P-14754-2

X1903

EXPOSED SURFACE

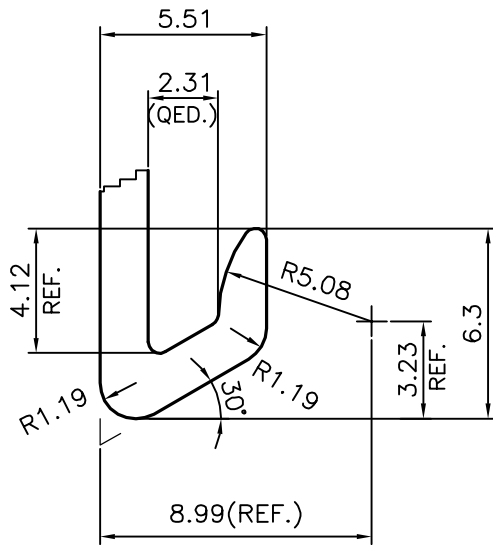

DETAIL "A"
SCALE 4:1

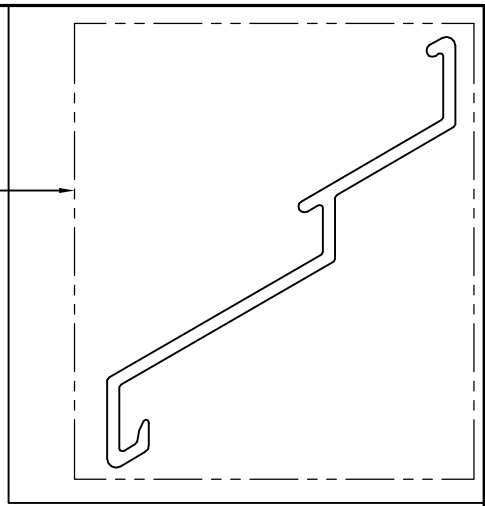
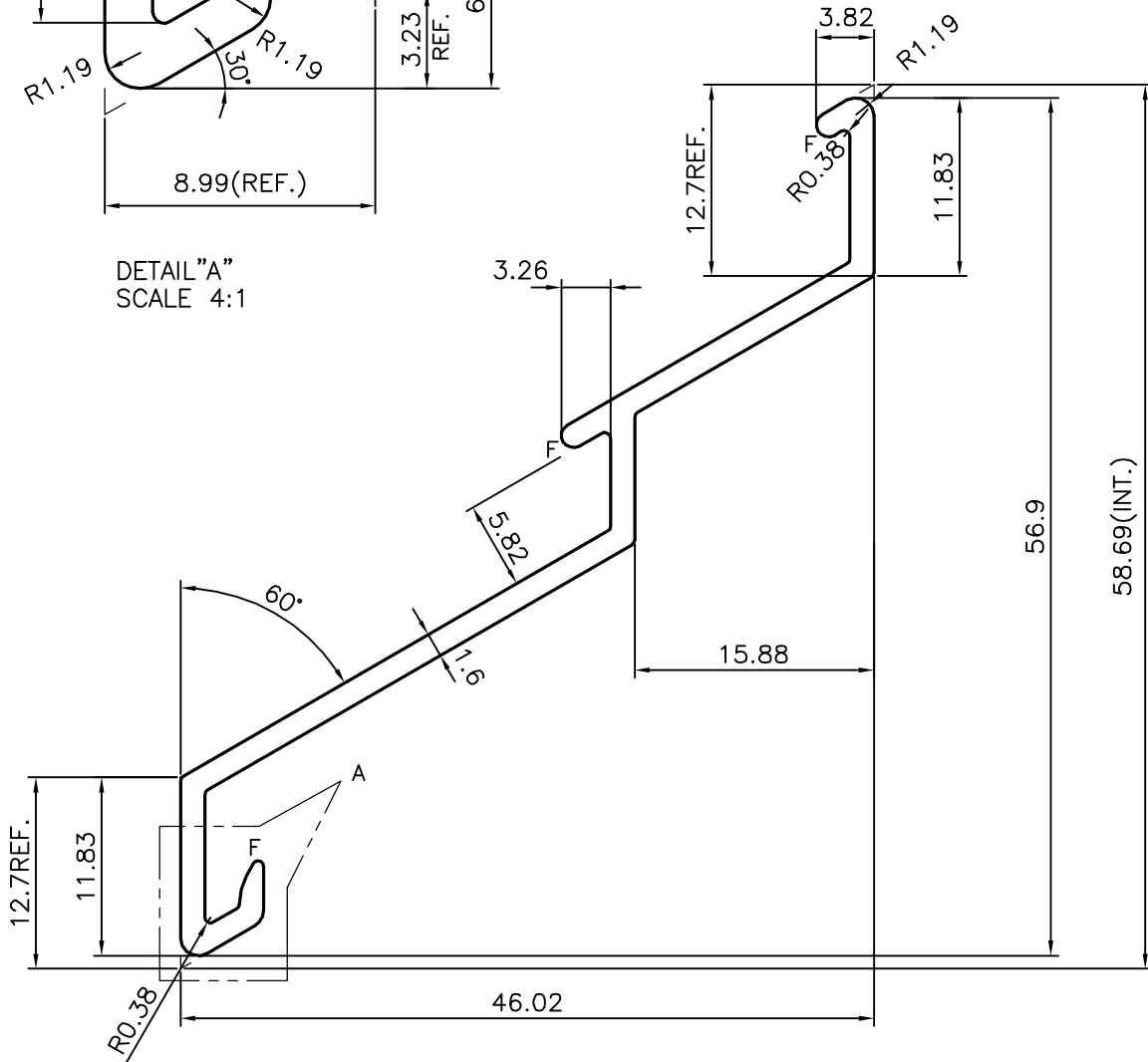

SYMBOL OF QUALITY
AN ISO 9001 COMPANY

JINDAL ALUMINIUM LTD.
BANGALORE-560073 (INDIA)

	NAME	DATE
DRAWN	J.P.KAUSHIK	06-07-2015
CHECKED		
APPROVED	B.NATARAJA	15-07-2015

1. ALL DIMENSIONS ARE IN mm.
2. ROUND OFF ALL SHARP CORNERS WITH 0.40 mm.
3. TOLERANCES WILL BE AS PER BS:EN-755-9 UNLESS OTHERWISE SPECIFIED

SCALE	2:1
AREA mm ²	151.262
PERIMETER mm.	188.514
WEIGHT kg/m	0.408

PARTY'S NAME	BADER AL MULLA & BROS. CO. W.L.L, KUWAIT
PARTY'S DRAWING No.	0011660-001 REV. A
ALLOY & TEMPER	6063 T5
DESCRIPTION	AIR GRILL SECTION

DRAWING No.	SECTION No.
P-14754-2	
X1903	X1903