

P-14905-1

X1911

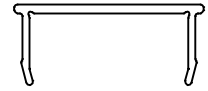

SCALE:- 1:1

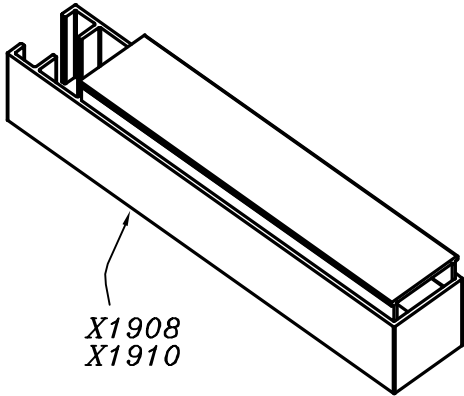
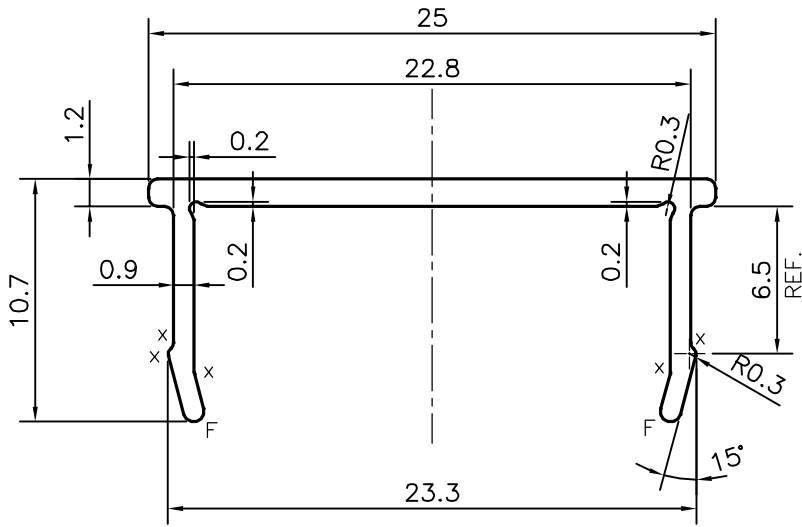

X1908
X1910

F = FULL RADIUS (2 PLACES)
X = RADIUS 0.3mm. (5 PLACES)

TOLERANCES ON OVERALL WIDTHS & WIDTHS ACROSS FLATS OF BARS, & REGULAR SECTIONS

| | | | |
|---------------------|----------------------|----------------------|---|
| UPTO 6.40mm - ±0.20 | UPTO 32.0mm - ±0.38 | UPTO 120.0mm - ±0.85 | 1. STRAIGHTNESS=1.7mm/M 2. TWIST=1.7mm/M 3. ANGULARITY= ±2° 4. FLATNESS =0.007xWIDTH |
| UPTO 10.0mm - ±0.23 | UPTO 50.0mm - ±0.46 | UPTO 160.0mm - ±1.02 | |
| UPTO 12.0mm - ±0.25 | UPTO 60.0mm - ±0.53 | UPTO 200.0mm - ±1.14 | |
| UPTO 16.0mm - ±0.28 | UPTO 80.0mm - ±0.69 | UPTO 250.0mm - ±1.40 | |
| UPTO 25.0mm - ±0.30 | UPTO 100.0mm - ±0.75 | UPTO 300.0mm - ±1.65 | |



SYMBOL OF QUALITY
AN ISO 9001 COMPANY

JINDAL ALUMINIUM LTD.
BANGALORE-560073 (INDIA)

| | NAME | DATE |
|----------|----------|------------|
| DRAWN | PARVESH | 04-08-2015 |
| CHECKED | | |
| APPROVED | S.S.GARG | 13-08-2015 |

1. ALL DIMENSIONS ARE IN mm.
2. ROUND OFF ALL SHARP CORNERS WITH 0.40 mm.
3. TOLERANCES WILL BE AS PER IS:3965-1981, UNLESS OTHERWISE SPECIFIED

| | |
|----------------------|--------|
| SCALE | 3:1 |
| AREA mm ² | 47.029 |
| PERIMETER mm. | 89.809 |
| WEIGHT kg/m | 0.127 |

| | |
|---------------------|------------------------------|
| PARTY'S NAME | FLOOR JINNI, BANGALORE |
| PARTY'S DRAWING No. | AS PER DRAWING & REQUIREMENT |
| ALLOY & TEMPER | HE9 WP |
| DESCRIPTION | GLAZING CLIP SECTION |

| DRAWING No. | SECTION No. |
|-------------|-------------|
| P-14905-1 | - |
| X1911 | X1911 |
| | |
| | |