

P-14742-1

X1918

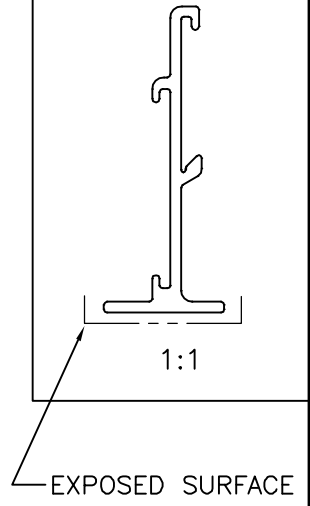

* = 1.52 RADIUS (3 PLACES)
 F = FULL RADIUS (3 PLACES)

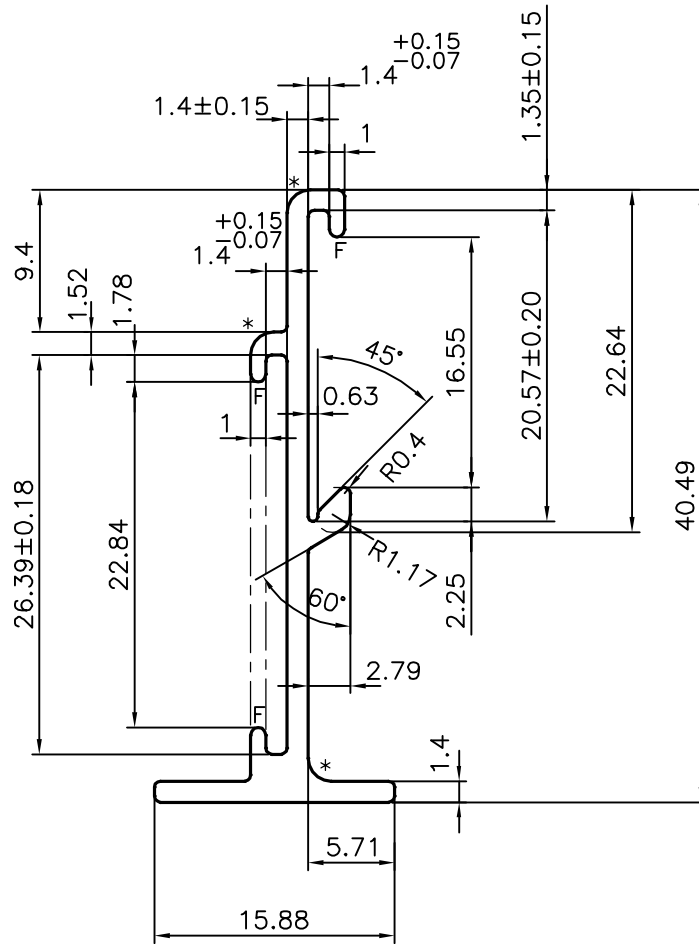

SYMBOL OF QUALITY
 AN ISO 9001 COMPANY

JINDAL ALUMINIUM LTD.
 BANGALORE-560073 (INDIA)

	NAME	DATE
DRAWN	J.P.KAUSHIK	17-06-2015
CHECKED		
APPROVED	S.S.GARG	01-10-2015
SCALE		2:1
AREA mm ²		99.121
PERIMETER mm.		134.838
WEIGHT kg/m		0.268

1. ALL DIMENSIONS ARE IN mm.
2. ROUND OFF ALL SHARP CORNERS WITH 0.40 mm.
3. TOLERANCES WILL BE AS PER BS:EN-755-9 UNLESS OTHERWISE SPECIFIED

PARTY'S NAME	BADER AL MULLA & BROS. CO. W.L.L, KUWAIT
PARTY'S DRAWING No.	5255
ALLOY & TEMPER	6063 T6
DESCRIPTION	AIR GRILL SECTION

DRAWING No.	SECTION No.
P-14742-1	
X1918	X1918