

P-14746-1

X1919

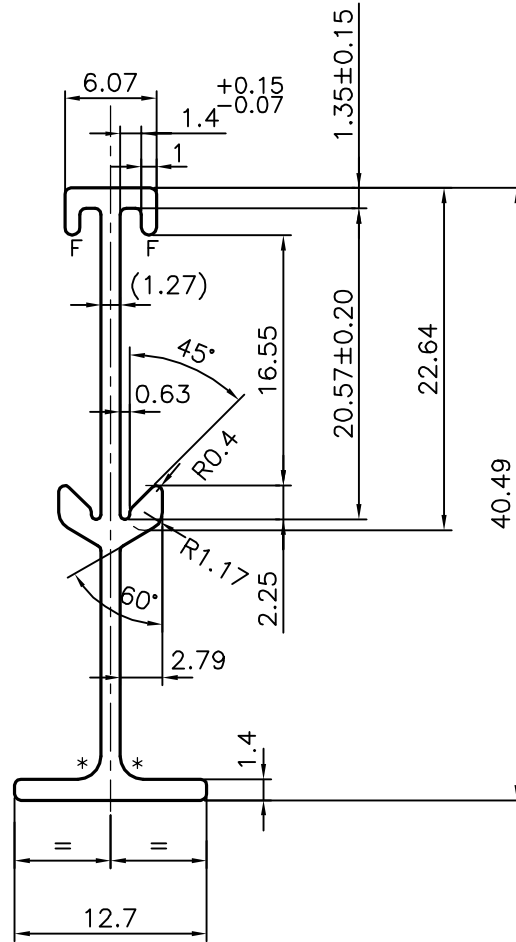

EXPOSED SURFACE

\* = 1.52 RADIUS (2 PLACES)  
 F = FULL RADIUS (2 PLACES)



SYMBOL OF QUALITY  
 AN ISO 9001 COMPANY

**JINDAL ALUMINIUM LTD.**  
 BANGALORE-560073 (INDIA)

	NAME	DATE
DRAWN	J.P.KAUSHIK	17-06-2015
CHECKED		
APPROVED	S.S.GARG	01-10-2015
SCALE		2:1
AREA mm <sup>2</sup>		90.948
PERIMETER mm.		133.852
WEIGHT kg/m		0.246

1. ALL DIMENSIONS ARE IN mm.
2. ROUND OFF ALL SHARP CORNERS WITH 0.40 mm.
3. TOLERANCES WILL BE AS PER BS:EN-755-9 UNLESS OTHERWISE SPECIFIED

PARTY'S NAME	BADER AL MULLA & BROS. CO. W.L.L, KUWAIT
PARTY'S DRAWING No.	5254
ALLOY & TEMPER	6063 T6
DESCRIPTION	AIR GRILL SECTION

DRAWING No.	SECTION No.
P-14746-1	
X1919	X1919