

P-15227

X1922

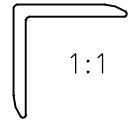

1:1

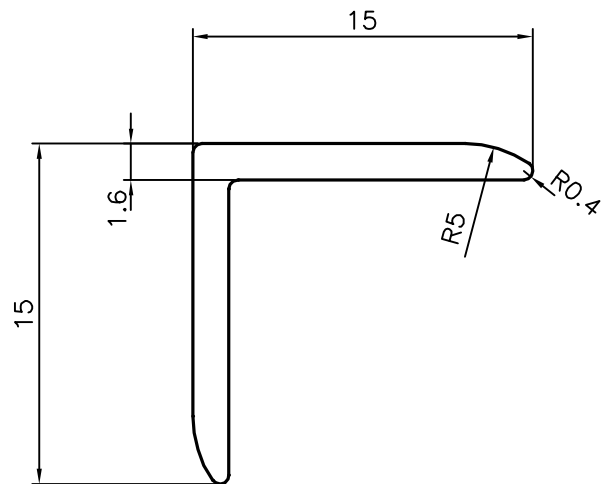

SYMBOL OF QUALITY
AN ISO 9001 COMPANY

JINDAL ALUMINIUM LTD.
BANGALORE-560073 (INDIA)

	NAME	DATE
DRAWN	J.P.KAUSHIK	08-10-2015
CHECKED		
APPROVED	S.S.GARG	10-10-2015
SCALE		3:1
AREA mm ²		43.461
PERIMETER mm.		57.693
WEIGHT kg/m		0.117
DRAWING No.	SECTION No.	
P-15227	-	
X1922	X1922	

1. ALL DIMENSIONS ARE IN mm.
2. ROUND OFF ALL SHARP CORNERS WITH 0.40 mm.
3. TOLERANCES WILL BE AS PER IS:3965-1981, UNLESS OTHERWISE SPECIFIED

PARTY'S NAME	FALANX FLOOR SOLUTIONS PVT. LTD., BANGALORE
PARTY'S DRAWING No.	CDR-9004143
ALLOY & TEMPER	HE9 WP
DESCRIPTION	EQUAL ANGLE-MISC.