

P-14756

X1924

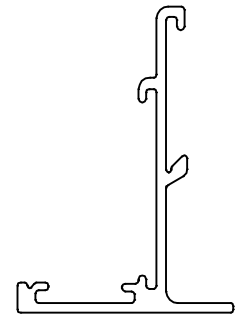
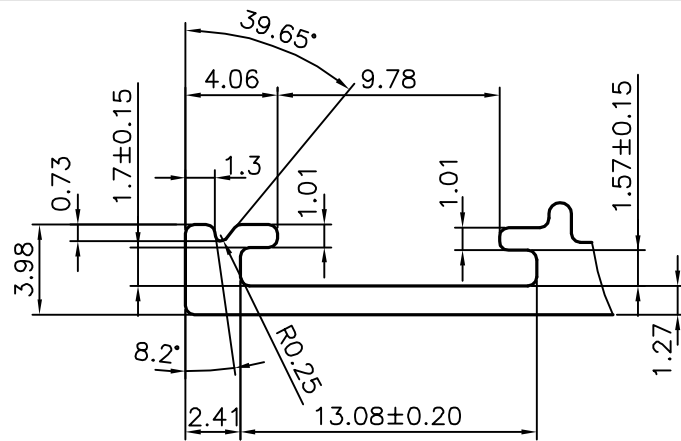

1:1

DETAIL "A"
SCALE 3:1

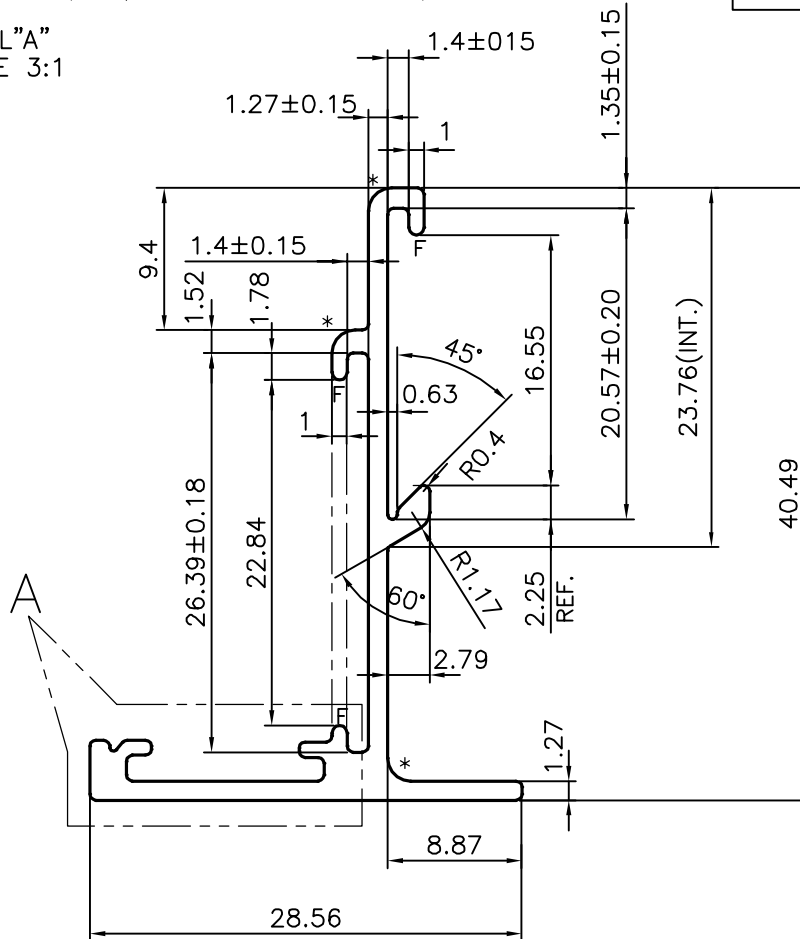

* = 1.52 RADIUS (3 PLACES)
F = FULL RADIUS (2 PLACES)



SYMBOL OF QUALITY
AN ISO 9001 COMPANY

JINDAL ALUMINIUM LTD.
BANGALORE-560073 (INDIA)

	NAME	DATE
DRAWN	J.P.KAUSHIK	30-07-2015
CHECKED		
APPROVED	S.S.GARG	05-11-2015
SCALE		2:1
AREA mm ²		119.302
PERIMETER mm.		171.622
WEIGHT kg/m		0.322

1. ALL DIMENSIONS ARE IN mm.
2. ROUND OFF ALL SHARP CORNERS WITH 0.40 mm.
3. TOLERANCES WILL BE AS PER BS:EN-755-9 UNLESS OTHERWISE SPECIFIED

PARTY'S NAME	BADER AL MULLA & BROS. CO. W.L.L, KUWAIT
PARTY'S DRAWING No.	4957
ALLOY & TEMPER	6060 T6
DESCRIPTION	AIR GRILL SECTION

DRAWING No.	SECTION No.
P-14756	
X1924	X1924