

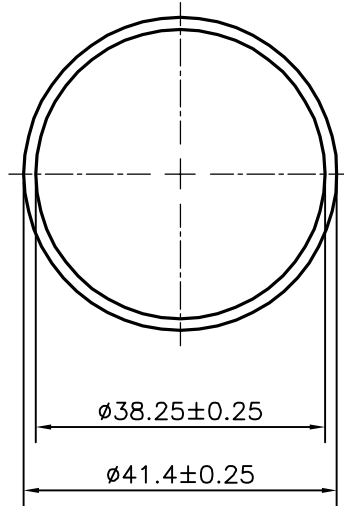

P-13617

X1932



STRAIGHTNESS :- 2.08 mm/ M
 ECCENTRICITY :- ±10% OF WALL THICKNESS

 SYMBOL OF QUALITY AN ISO 9001 COMPANY	JINDAL ALUMINIUM LTD. BANGALORE-560073 (INDIA)		NAME	DATE
		DRAWN	<i>PARVESH</i>	28-05-2014
1. ALL DIMENSIONS ARE IN mm. 2. ROUND OFF ALL SHARP CORNERS WITH 0.40 mm. 3. TOLERANCES WILL BE AS PER ANSI:H35.2-2009 , UNLESS OTHERWISE SPECIFIED		CHECKED		
		APPROVED	S.S.GARG	21-11-2015
PARTY'S NAME GEORGIA IMPORT & TRADING CO., USA		SCALE		1:1
		AREA mm ²		197.054
PARTY'S DRAWING No. AS PER SPECIFICATION		PERIMETER mm.		130.062
		WEIGHT kg/m		0.532
ALLOY & TEMPER 6063 T6		DRAWING No.	SECTION No.	
		P-13617	-	
DESCRIPTION ROUND TUBE		X1932	X1932	