

P-15322-1

X1935

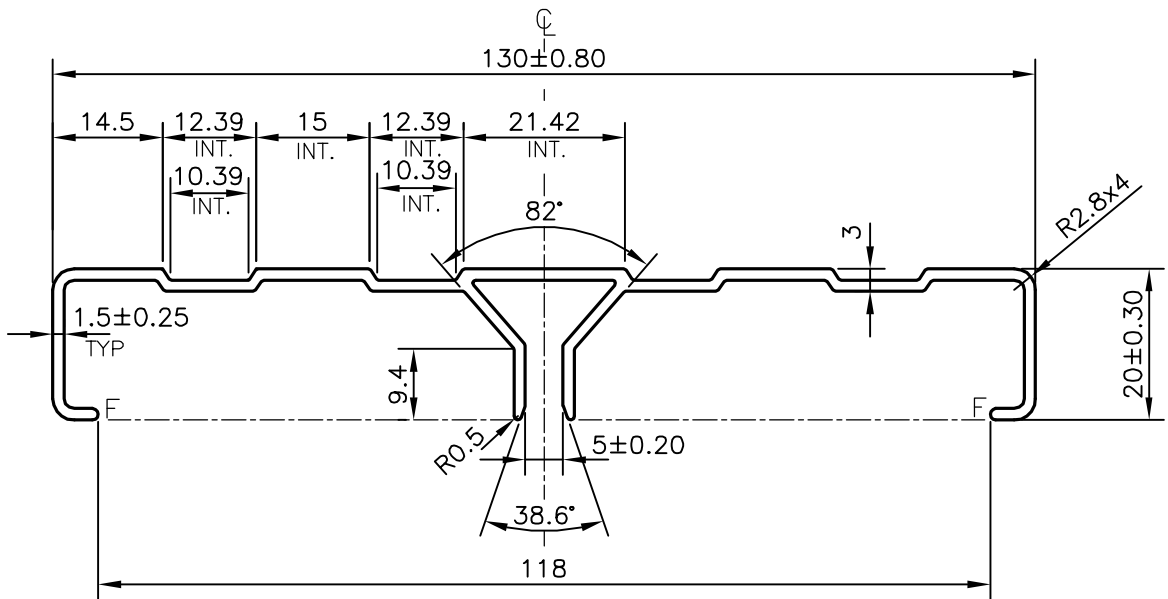

F = FULL RADIUS (2PLACE)

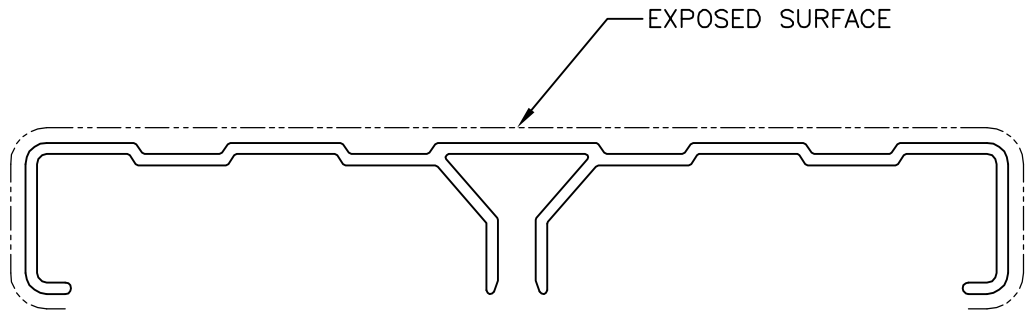

SYMBOL OF QUALITY
AN ISO 9001 COMPANY

JINDAL ALUMINIUM LTD.
BANGALORE-560073 (INDIA)

	NAME	DATE
DRAWN	J.P.KAUSHIK	24-11-2015
CHECKED		
APPROVED	S.S.GARG	01-12-2015
SCALE		1:1
AREA mm ²		328.422
PERIMETER mm.		436.589
WEIGHT kg/m		0.887
DRAWING No.	SECTION No.	
P-15322-1	-	
X1935	X1935	

1. ALL DIMENSIONS ARE IN mm.
2. ROUND OFF ALL SHARP CORNERS WITH 0.40 mm.
3. TOLERANCES WILL BE AS PER BS:EN-12020-2 , UNLESS OTHERWISE SPECIFIED

PARTY'S NAME	TEAM CONCEPTS PVT. LTD., BANGALORE
PARTY'S DRAWING No.	660A-LAB-000
ALLOY & TEMPER	6063 T5
DESCRIPTION	LOAD ALUMINUM BIG SECTION