

P-15324-1

X1937

EXPOSED SURFACE

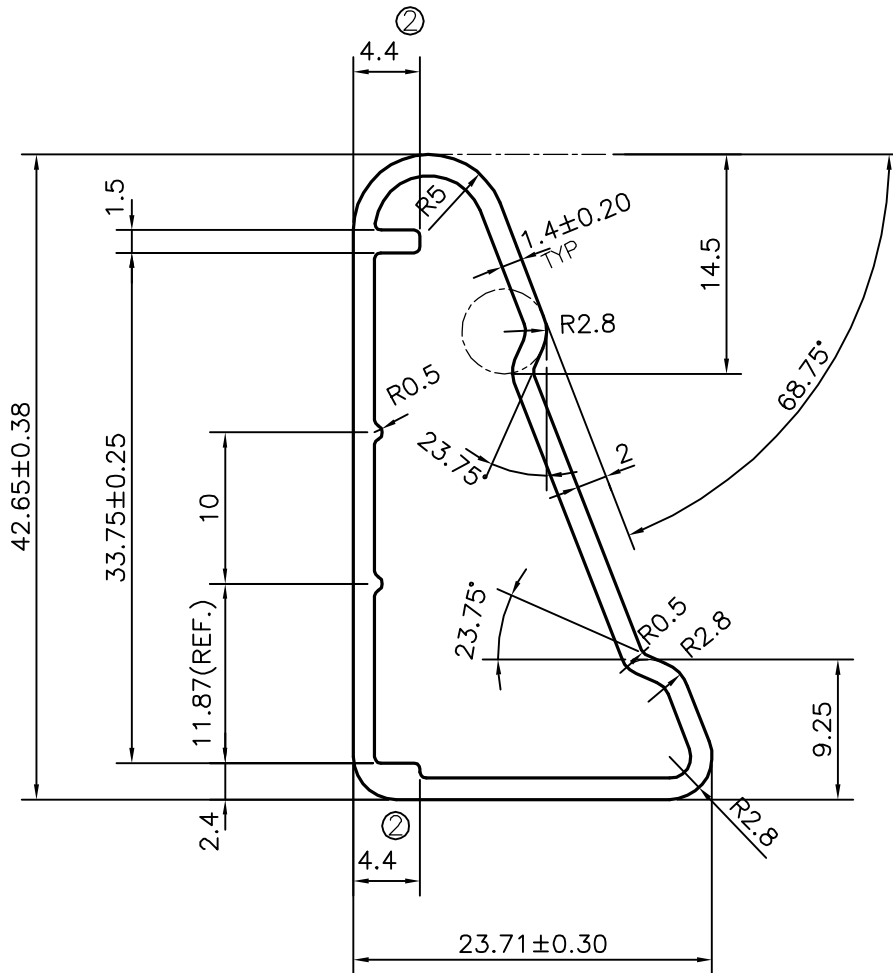
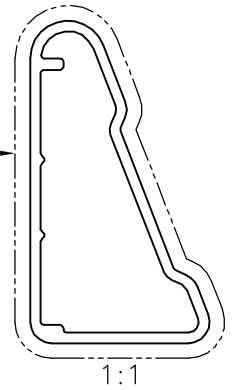

**ISSUE (2) :-**

DIMENSION CHANGED FROM 3.4 mm TO 4.4 mm

WEIGHT ALSO CHANGED FROM 0.438 kg/m. TO 0.444 kg/m.



SYMBOL OF QUALITY  
AN ISO 9001 COMPANY

**JINDAL ALUMINIUM LTD.**  
BANGALORE-560073 (INDIA)

	NAME	DATE
DRAWN	J.P.KAUSHIK	30-12-2015
CHECKED		
APPROVED	S.S.GARG	31-12-2015
SCALE		2:1
AREA mm <sup>2</sup>		164.589
PERIMETER mm.		116.28
WEIGHT kg/m		0.444
DRAWING No.	SECTION No.	
P-15324-1	-	
X1937	X1937(ISSUE-2)	

1. ALL DIMENSIONS ARE IN mm.
2. ROUND OFF ALL SHARP CORNERS WITH 0.40 mm.
3. TOLERANCES WILL BE AS PER BS:EN-12020-2 , UNLESS OTHERWISE SPECIFIED

PARTY'S NAME: TEAM CONCEPTS PVT. LTD., BANGALORE

PARTY'S DRAWING No.: 660A-SS-000

ALLOY & TEMPER: 6063 T5

DESCRIPTION: SIDE PROFILE SECTION