

P-15392

X1956

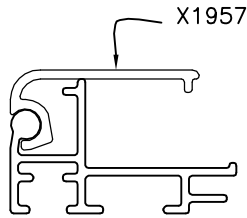

EXPOSED SURFACE

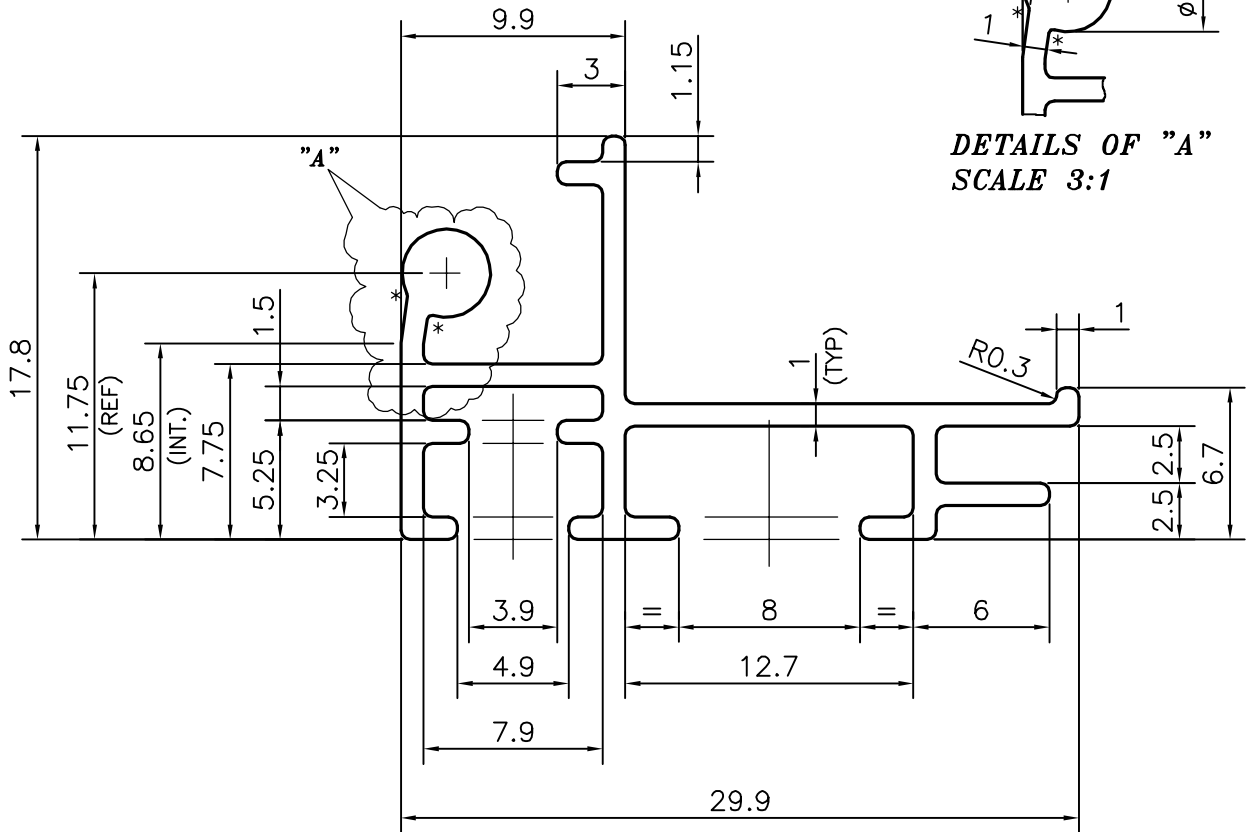
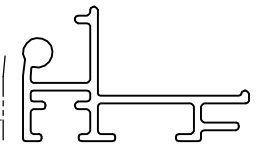

DETAILS OF "A"
SCALE 3:1

* = 0.20 RADIUS (2 PLACES)



SYMBOL OF QUALITY
AN ISO 9001 COMPANY

JINDAL ALUMINIUM LTD.
BANGALORE-560073 (INDIA)

	NAME	DATE
DRAWN	J.P.KAUSHIK	05-12-2015
CHECKED		
APPROVED	S.S.GARG	08-01-2016

1. ALL DIMENSIONS ARE IN mm.
2. ROUND OFF ALL SHARP CORNERS WITH 0.40 mm.
3. TOLERANCES WILL BE AS PER IS:3965-1981, UNLESS OTHERWISE SPECIFIED

SCALE	3:1
AREA mm ²	92.298
PERIMETER mm.	165.362
WEIGHT kg/m	0.249

PARTY'S NAME ELCARE SYSTEMS PVT. LTD., COCHIN

DRAWING No. SECTION No.

PARTY'S DRAWING No. AS PER SAMPLE

P-15392
X1956 X1956

ALLOY & TEMPER HE9 WP

DESCRIPTION DISPLAY SECTION