

P-15503

X1960

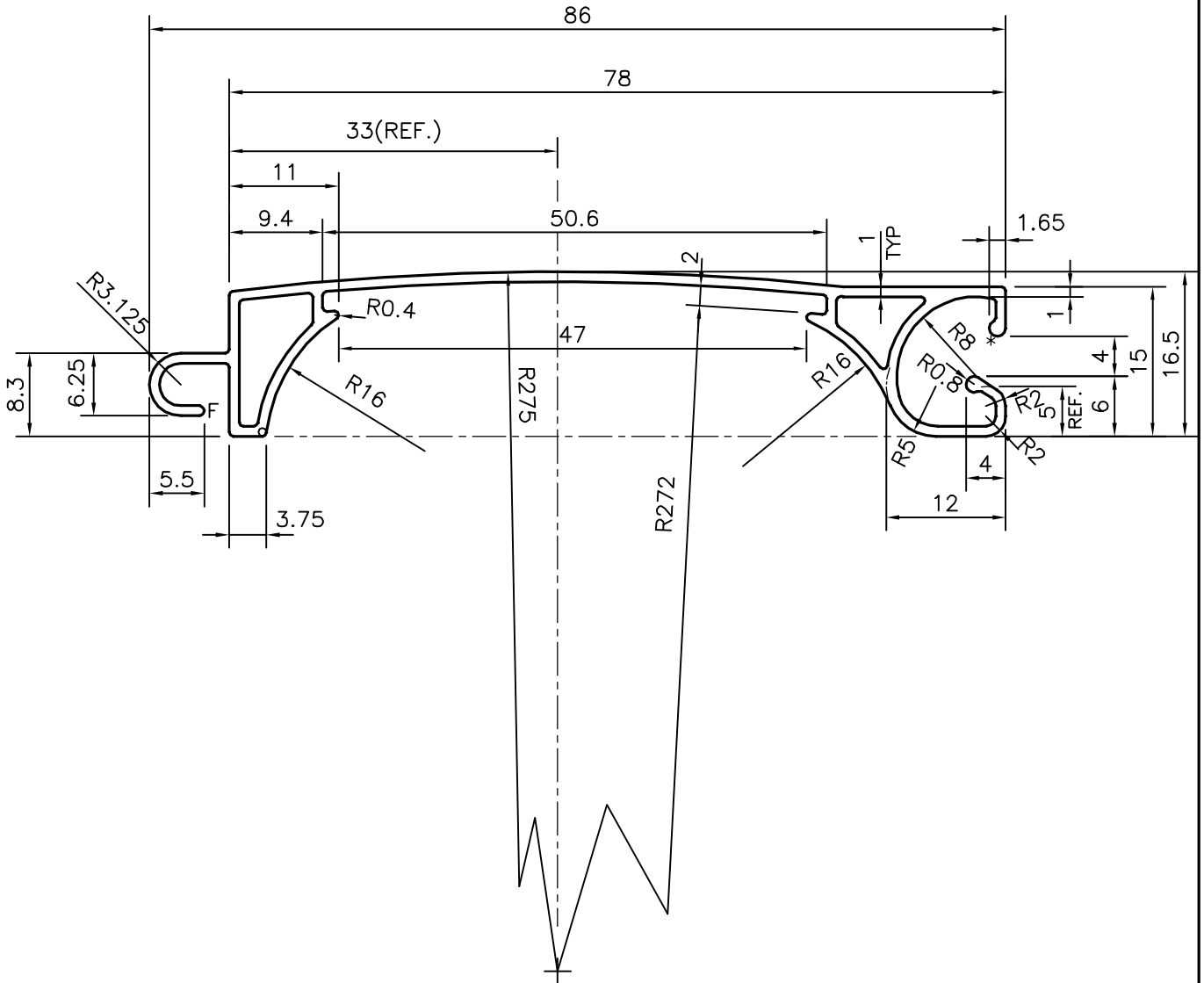

F = FULL RADIUS
 * = 0.825 RADIUS

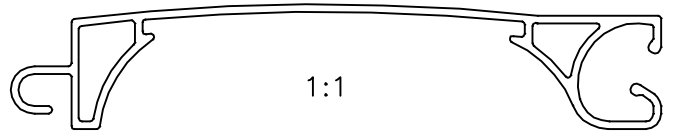

SYMBOL OF QUALITY
 AN ISO 9002 COMPANY

JINDAL ALUMINIUM LTD.
 BANGALORE-560073 (INDIA)

	NAME	DATE
DRAWN	J.P.KAUSHIK	13-01-2016
CHECKED		
APPROVED	S.S.GARG	23-01-2016
SCALE		1.5:1
AREA mm ²		178.826
PERIMETER mm.		275.418
WEIGHT kg/m		0.483
DRAWING No.	SECTION No.	
P-15503	-	
X1960	X1960	

1. ALL DIMENSIONS ARE IN mm.
2. ROUND OFF ALL SHARP CORNERS WITH 0.40 mm.
3. TOLERANCES WILL BE AS PER IS:6477-1983 UNLESS OTHERWISE SPECIFIED

PARTY'S NAME	ARIHANT ALUMINIUM CORPORATION, BANGALORE
PARTY'S DRAWING No.	AS PER SAMPLE
ALLOY & TEMPER	HE9 WP
DESCRIPTION	MISC. SECTION