

P-15537

X1962

EXPOSED SURFACE

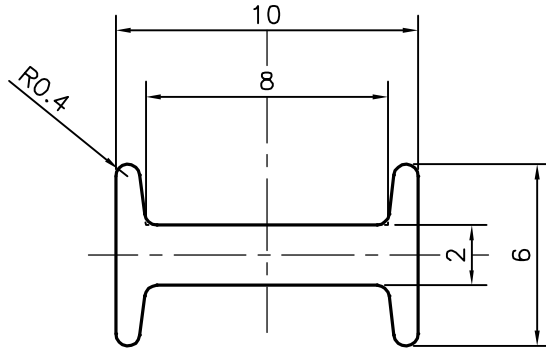
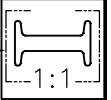

SYMBOL OF QUALITY  
AN ISO 9001 COMPANY

**JINDAL ALUMINIUM LTD.**  
BANGALORE-560073 (INDIA)

	NAME	DATE
DRAWN	J.P.KAUSHIK	25-01-2016
CHECKED		
APPROVED	S.S.GARG	01-02-2016
SCALE		4:1
AREA mm <sup>2</sup>		26.878
PERIMETER mm.		37.363
WEIGHT kg/m		0.073
DRAWING No.	SECTION No.	
P-15537	-	
X1962	X1962	

1. ALL DIMENSIONS ARE IN mm.
2. ROUND OFF ALL SHARP CORNERS WITH 0.40 mm.
3. TOLERANCES WILL BE AS PER, IS:3965-1981 UNLESS OTHERWISE SPECIFIED

PARTY'S NAME	HYTEK INTERIOR PRODUCTS., BANGALORE
PARTY'S DRAWING No.	AS PER AutoCAD DRAWING
ALLOY & TEMPER	HE9 WP
DESCRIPTION	MISC. SECTION