

P-15645-1

X1972

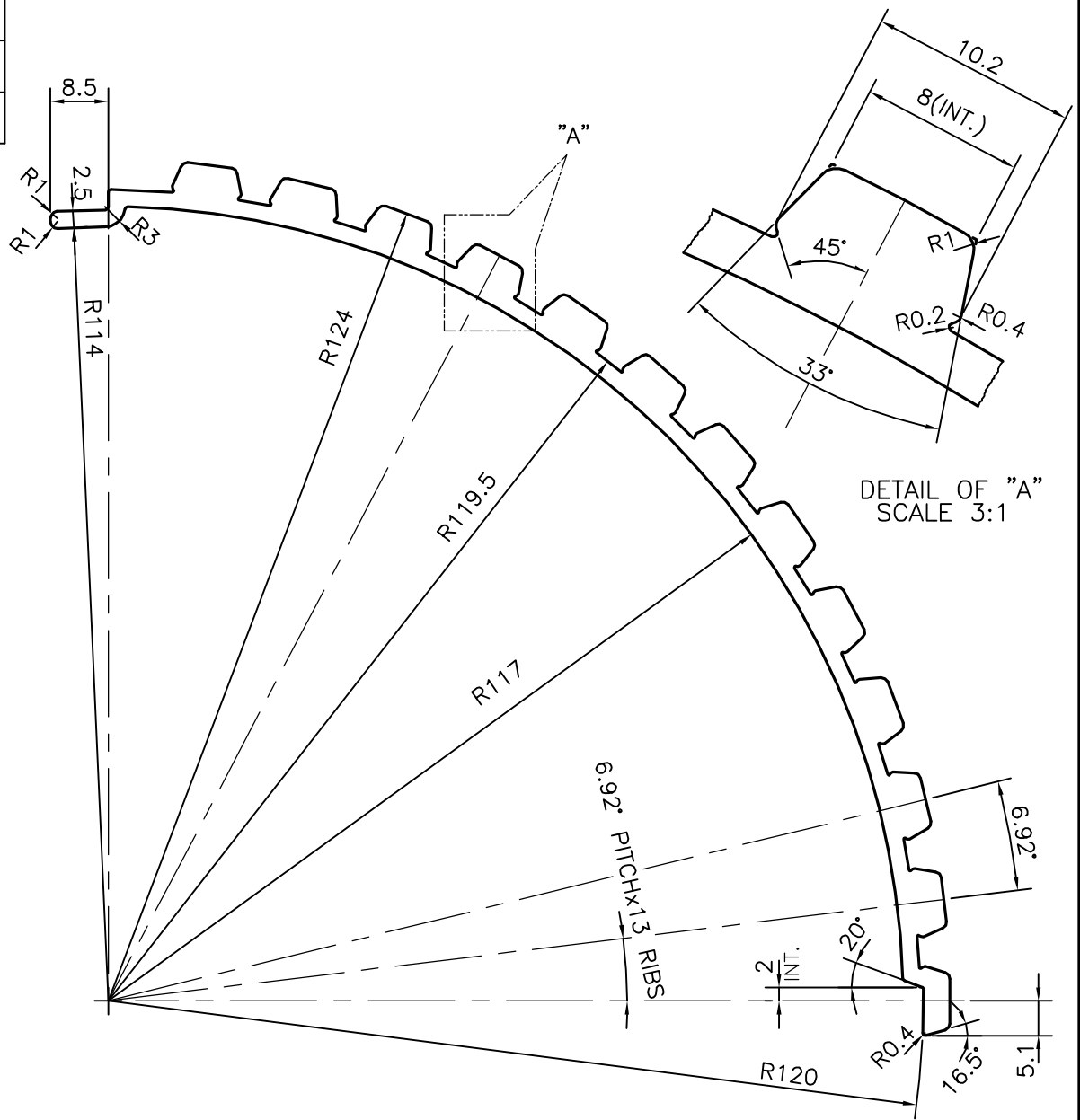

SYMBOL OF QUALITY
AN ISO 9001 COMPANY

JINDAL ALUMINIUM LTD.
BANGALORE-560073 (INDIA)

	NAME	DATE
DRAWN	J.P.KAUSHIK	04-03-2016
CHECKED		
APPROVED	S.S.GARG	15-03-2016
SCALE		1:1
AREA mm ²		1019.093
PERIMETER mm.		502.823
WEIGHT kg/m		2.752
DRAWING No.	SECTION No.	
P-15645-1	-	
X1972	X1972	

1. ALL DIMENSIONS ARE IN mm.
2. ROUND OFF ALL SHARP CORNERS WITH 0.40 mm.
3. TOLERANCES WILL BE AS PER BS:EN-755-9 UNLESS OTHERWISE SPECIFIED

PARTY'S NAME	GOLDSPAR AUSTRALIA PTY LTD., AUSTRALIA
PARTY'S DRAWING No.	2366450 234 CLADDING
ALLOY & TEMPER	6063 T6
DESCRIPTION	MISC. SECTION