

P-15689

X1979

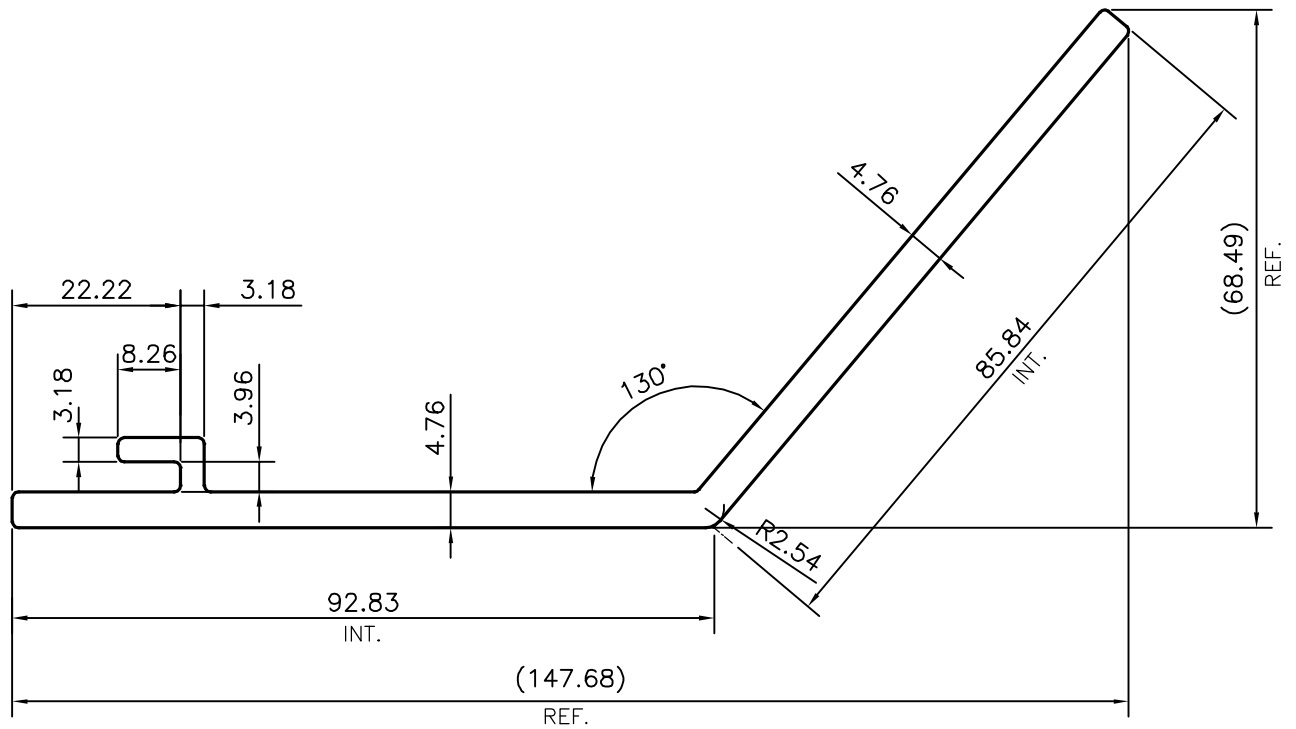

ROUND OFF ALL SHARP CORNERS WITH 0.80 mm.



SYMBOL OF QUALITY
AN ISO 9001 COMPANY

JINDAL ALUMINIUM LTD.
BANGALORE-560073 (INDIA)

	NAME	DATE
DRAWN	PARVESH	18-03-2016
CHECKED		
APPROVED	S.S. GARG	04-04-2016
SCALE		1:1
AREA mm ²		888.152
PERIMETER mm.		389.587
WEIGHT kg/m		2.398
DRAWING No.	SECTION No.	
P-15689	-	
X1979	X1979	

1. ALL DIMENSIONS ARE IN mm.
2. ROUND OFF ALL SHARP CORNERS WITH 0.40 mm.
3. TOLERANCES WILL BE AS PER ANSI:H35.2-2009 , UNLESS OTHERWISE SPECIFIED

PARTY'S NAME	LUCID MANAGEMENT GROUP, CANADA
PARTY'S DRAWING No.	1005963
ALLOY & TEMPER	6005 T5
DESCRIPTION	STRUCTURAL MISC. SECTION-FRONT BEAM COVER