

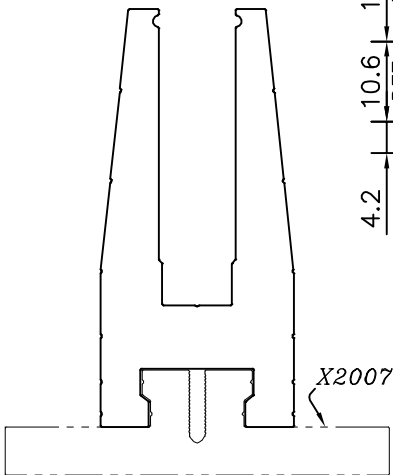

P-15733

X2006

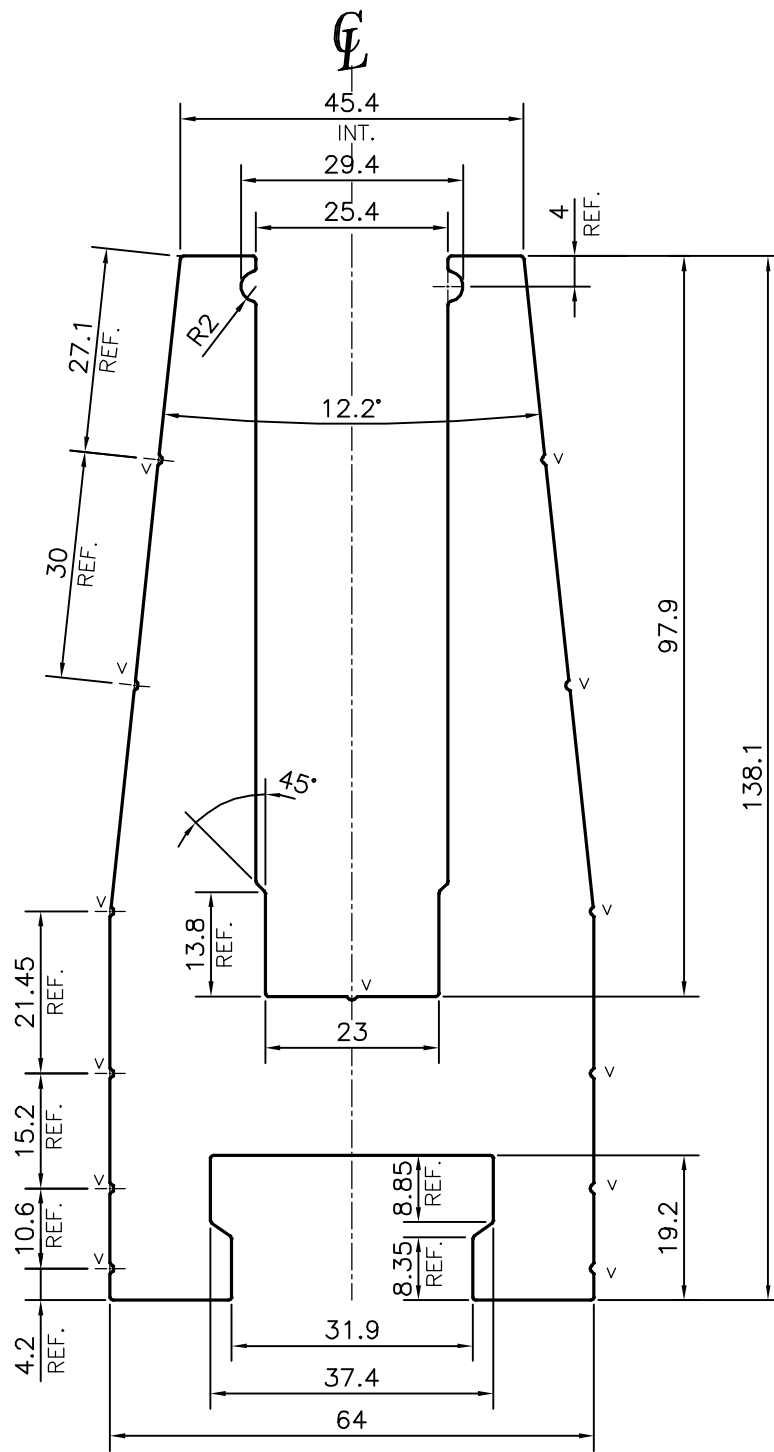

SCALE: -0.4:1

V = VEE GROOVE 0.5x90° (13 PLACES)

 SYMBOL OF QUALITY AN ISO 9001 COMPANY	JINDAL ALUMINIUM LTD. BANGALORE-560073 (INDIA)	NAME	DATE
		DRAWN	PARVESH 31-03-2016
		CHECKED	
		APPROVED	S.S. GARG 18-04-2016
		SCALE	1:1
		AREA mm ²	4891.855
		PERIMETER mm.	634.246
		WEIGHT kg/m	13.208
PARTY'S NAME	PROSOURCE INDL. SOLUTIONS INC., CANADA	DRAWING No.	SECTION No.
PARTY'S DRAWING No.	AS PER AUTOCAD DRAWING	P-15733	-
ALLOY & TEMPER	6063 T5	X2006	X2006
DESCRIPTION	MISC. SECTION		