

P-15734

X2007

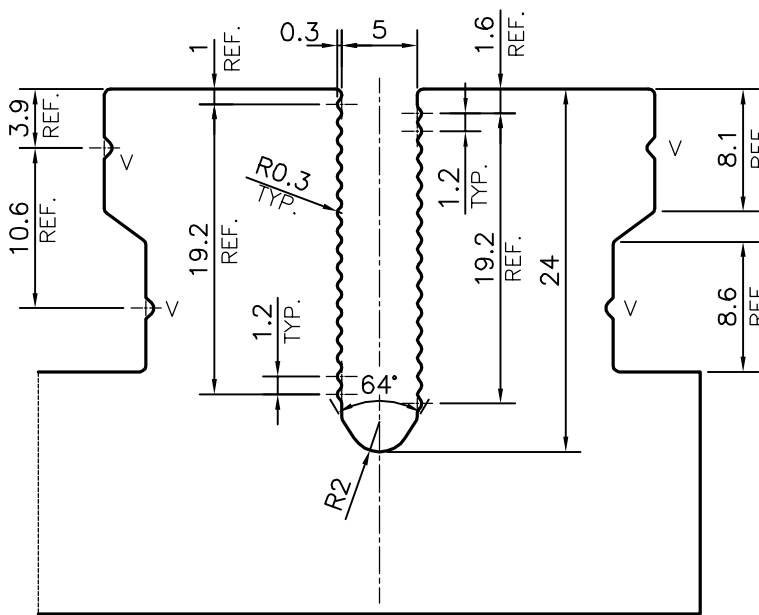

DETAIL OF "A"  
SCALE 2:1

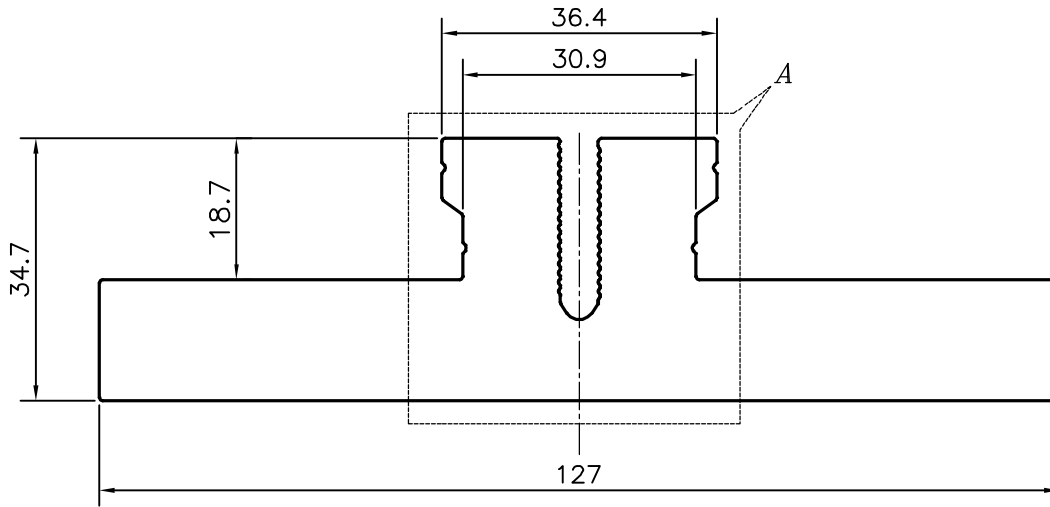
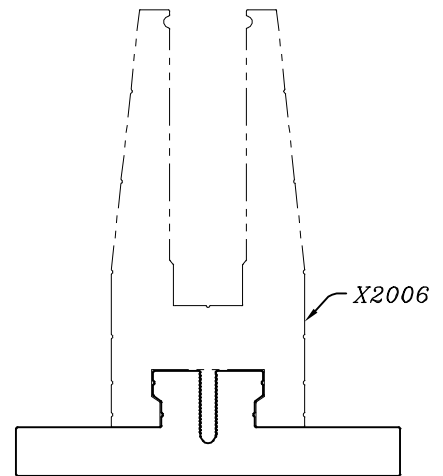

SCALE: -0.4:1

V = VEE GROOVE 0.5x90° (4 PLACES)



SYMBOL OF QUALITY  
AN ISO 9001 COMPANY

**JINDAL ALUMINIUM LTD.**  
BANGALORE-560073 (INDIA)

	NAME	DATE
DRAWN	PARVESH	31-03-2016
CHECKED		
APPROVED	S.S. GARG	18-04-2016
SCALE		1:1
AREA mm <sup>2</sup>		2535.272
PERIMETER mm.		382.846
WEIGHT kg/m		6.845
DRAWING No.	SECTION No.	
P-15734	-	
X2007	X2007	

1. ALL DIMENSIONS ARE IN mm.
2. ROUND OFF ALL SHARP CORNERS WITH 0.40 mm.
3. TOLERANCES WILL BE AS PER BS:EN-755-9 , UNLESS OTHERWISE SPECIFIED

PARTY'S NAME	PROSOURCE INDL. SOLUTIONS INC., CANADA
PARTY'S DRAWING No.	AS PER AUTOCAD DRAWING
ALLOY & TEMPER	6063 T5
DESCRIPTION	MISC. SECTION