

P-14751-1

X2019

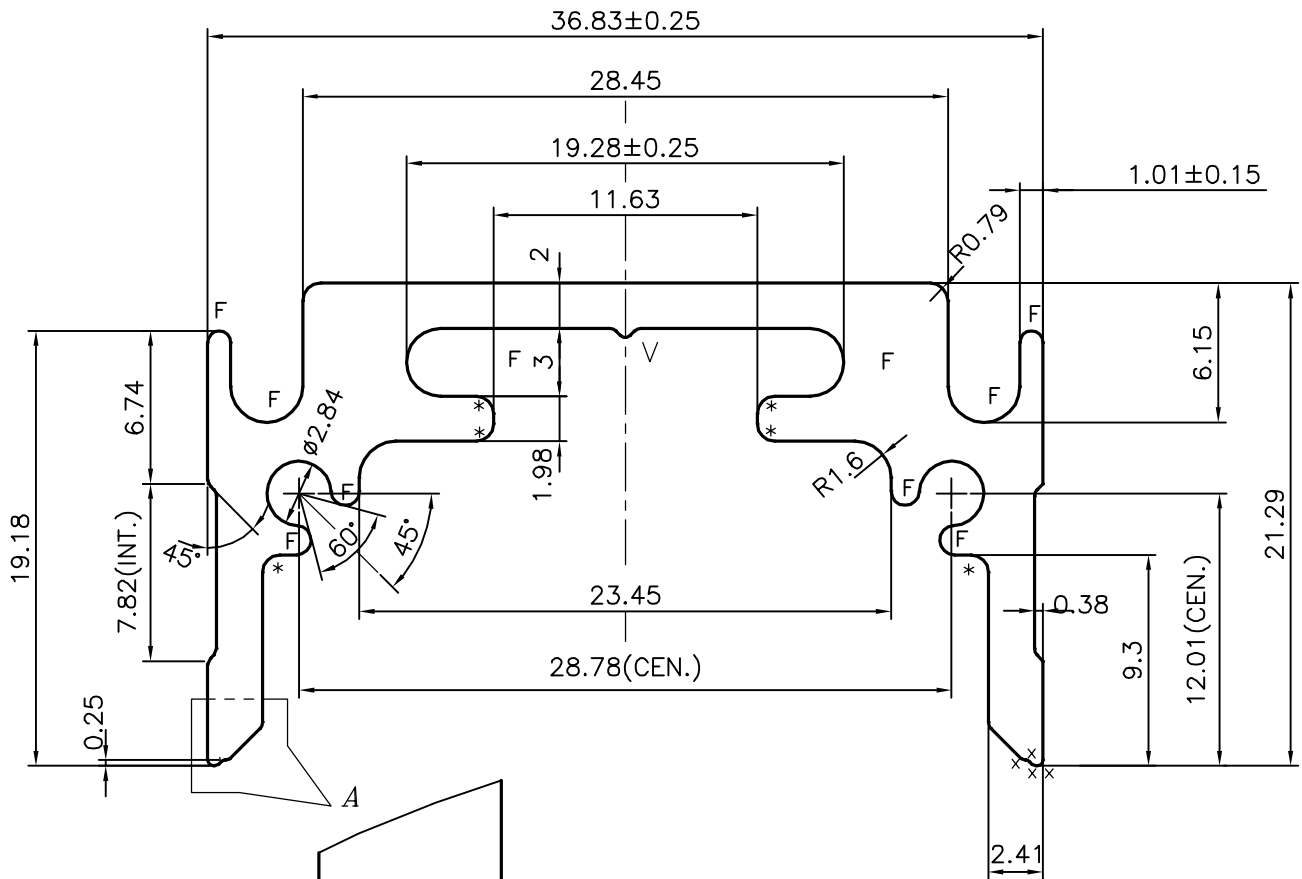

DETAIL OF "A"
SCALE 10:1

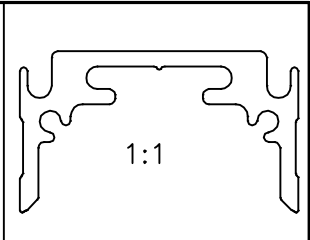
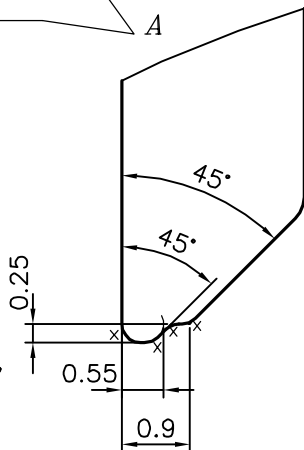

- x = 0.25 RADIUS (8 PLACES)
- V = V GROOVE 0.4x90°
- * = 0.76 RADIUS (6 PLACES)
- F = FULL RADIUS (4 PLACES)



SYMBOL OF QUALITY
AN ISO 9001 COMPANY

JINDAL ALUMINIUM LTD.
BANGALORE-560073 (INDIA)

	NAME	DATE
DRAWN	J.P.KAUSHIK	31-07-2015
CHECKED		
APPROVED	S.S. GARG	03-06-2016

1. ALL DIMENSIONS ARE IN mm.
2. ROUND OFF ALL SHARP CORNERS WITH 0.40 mm.
3. TOLERANCES WILL BE AS PER BS:EN-755-9 UNLESS OTHERWISE SPECIFIED

SCALE	3:1
AREA mm ²	218.555
PERIMETER mm.	184.275
WEIGHT kg/m	0.590

PARTY'S NAME	BADER AL MULLA & BROS. CO. W.L.L, KUWAIT
PARTY'S DRAWING No.	5136
ALLOY & TEMPER	6060 T6
DESCRIPTION	AIR GRILL SECTION

DRAWING No.	SECTION No.
P-14751-1	
X2019	X2019