

P-16289

X2072

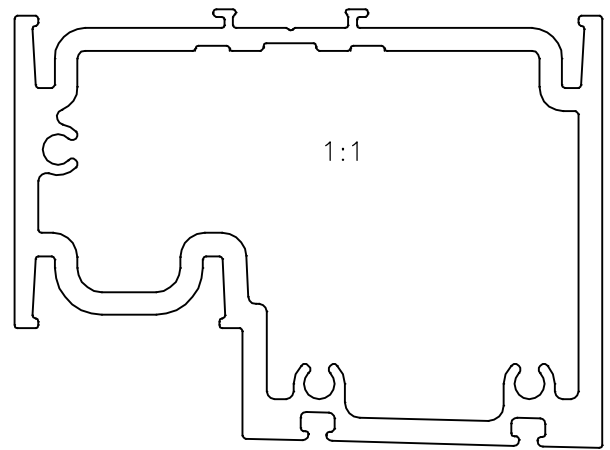

1:1

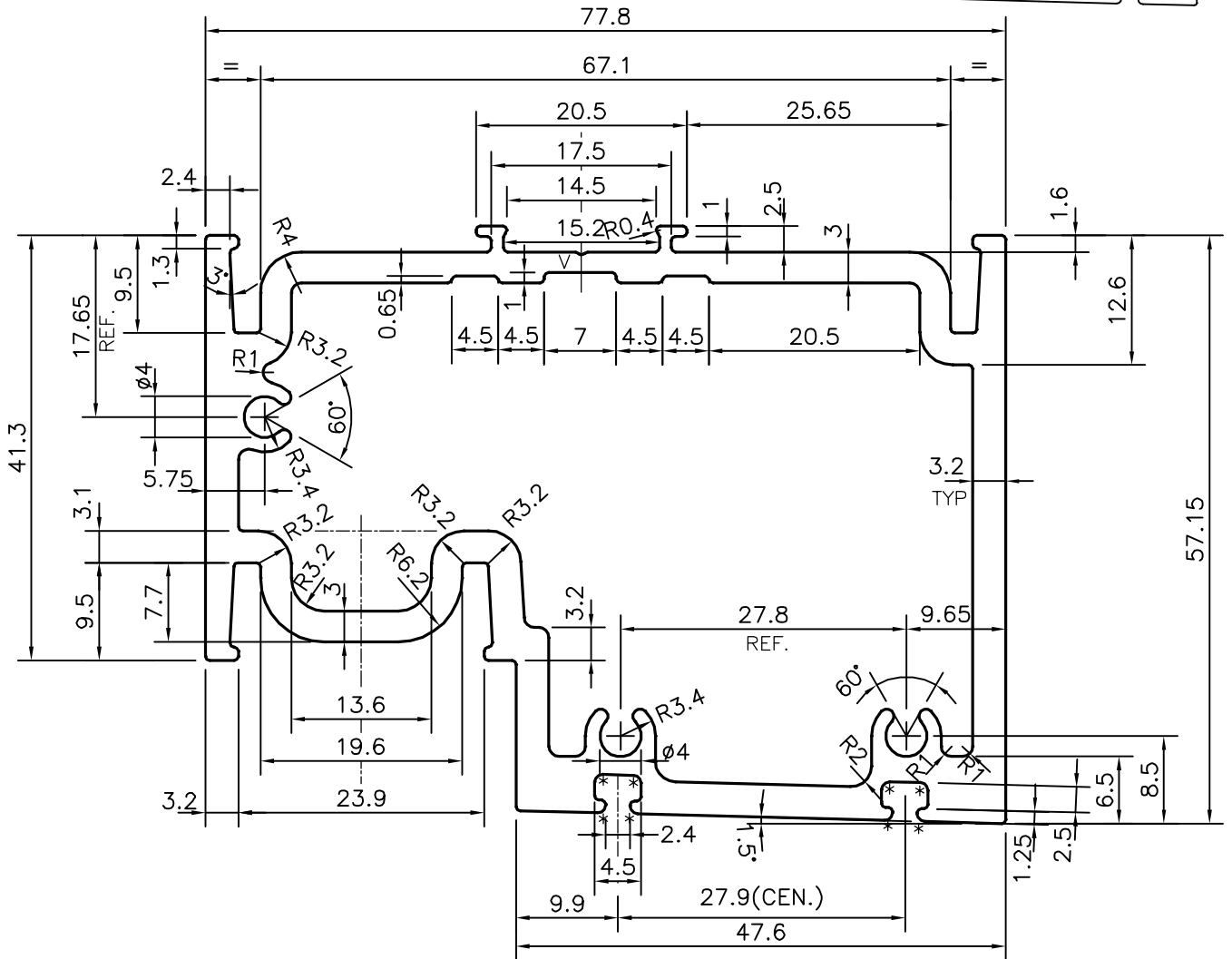

V = V GROOVE 0.3x90°
 * = 0.75 RADIUS (8 PLACES)



SYMBOL OF QUALITY
 AN ISO 9001 COMPANY

JINDAL ALUMINIUM LTD.
 BANGALORE-560073 (INDIA)

	NAME	DATE
DRAWN	J.P.KAUSHIK	02-09-2016
CHECKED		
APPROVED	S.S.GARG	11-09-2016

- ALL DIMENSIONS ARE IN mm.
- ROUND OFF ALL SHARP CORNERS WITH 0.40 mm.
- TOLERANCES WILL BE AS PER BS:EN-755-9 UNLESS OTHERWISE SPECIFIED

SCALE	1.5:1
AREA mm ²	957.486
PERIMETER mm.	364.076
WEIGHT kg/m	2.585

PARTY'S NAME	PROSOURCE INDL. SOLUTIONS INC., CANADA
PARTY'S DRAWING No.	AS PER DRAWING
ALLOY & TEMPER	6063 T5
DESCRIPTION	MISC. SECTION

DRAWING No.	SECTION No.
P-16289	-
X2072	X2072