

P-16050

S5045

X2087

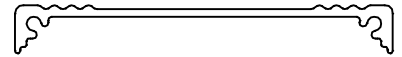
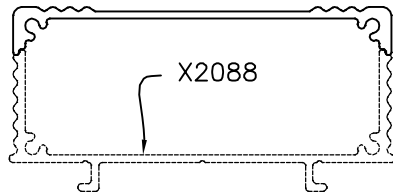

SCALE:- 1:1

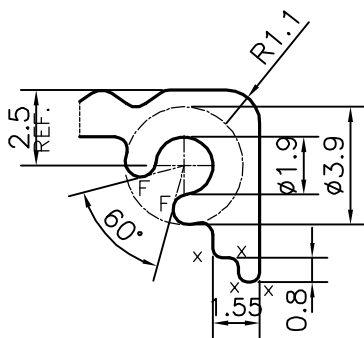
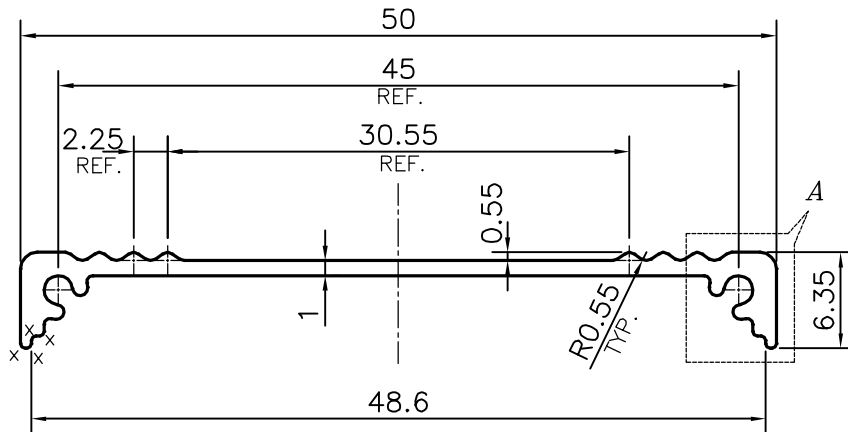

DETAIL OF "A"  
SCALE 4:1

X = RADIUS 0.3 mm. (8 PLACES)  
F = FULL RADIUS (4 PLACES)



SYMBOL OF QUALITY  
AN ISO 9001 COMPANY

**JINDAL ALUMINIUM LTD.**  
BANGALORE-560073 (INDIA)

	NAME	DATE
DRAWN	PARVESH	01-07-2016
CHECKED		
APPROVED	S.S. GARG	26-07-2016
SCALE		2:1
AREA mm <sup>2</sup>		76.514
PERIMETER mm.		128.453
WEIGHT kg/m		0.207
DRAWING No.	SECTION No.	
P-16050	-	
S5045	S5045	
X2087	X2087	

1. ALL DIMENSIONS ARE IN mm.
2. ROUND OFF ALL SHARP CORNERS WITH 0.40 mm.
3. TOLERANCES WILL BE AS PER IS:3965-1981, UNLESS OTHERWISE SPECIFIED

PARTY'S NAME	VYOMA LITES, BANGALORE
PARTY'S DRAWING No.	AS PER AUTOCAD DRAWING-REQUIREMENT
ALLOY & TEMPER	HE9 WP
DESCRIPTION	ELECTRICAL SECTION