

P-16052

S5047

X2089

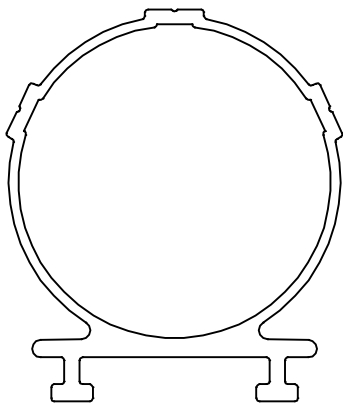
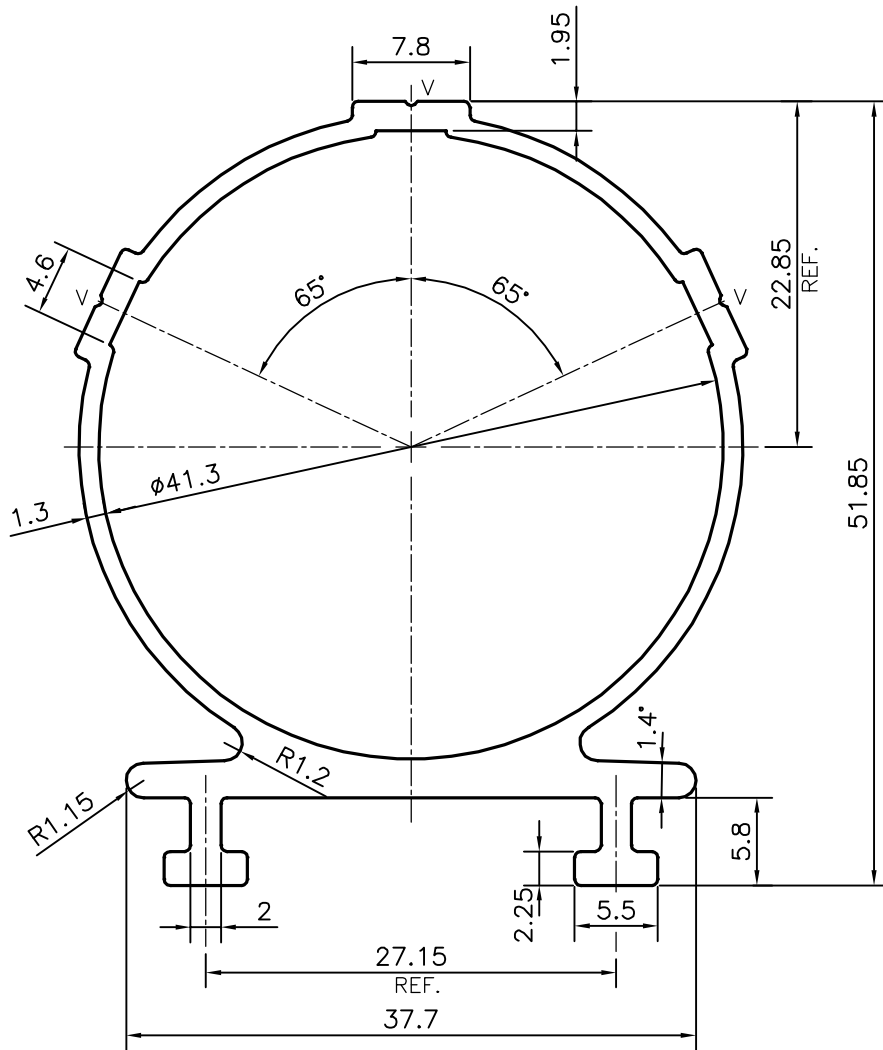

SCALE:- 1:1

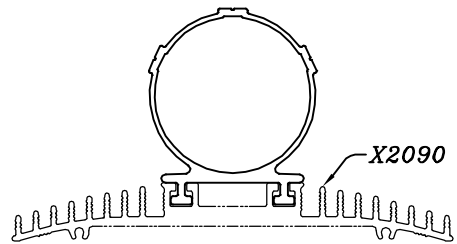

SCALE:- 0.5:1

V = VEE GGROOVE 0.3x90° (3 PLACES)



SYMBOL OF QUALITY  
AN ISO 9001 COMPANY

**JINDAL ALUMINIUM LTD.**  
BANGALORE-560073 (INDIA)

	NAME	DATE
DRAWN	PARVESH	01-07-2016
CHECKED		
APPROVED	S.S. GARG	26-07-2016
SCALE		2:1
AREA mm <sup>2</sup>		317.912
PERIMETER mm.		213.456
WEIGHT kg/m		0.858
DRAWING No.	SECTION No.	
P-16052	-	
S5047	S5047	
X2089	X2089	

1. ALL DIMENSIONS ARE IN mm.
2. ROUND OFF ALL SHARP CORNERS WITH 0.40 mm.
3. TOLERANCES WILL BE AS PER IS:6477-1983 , UNLESS OTHERWISE SPECIFIED

PARTY'S NAME	VYOMA LITES, BANGALORE
PARTY'S DRAWING No.	AS PER AUTOCAD DRAWING-REQUIREMENT
ALLOY & TEMPER	HE9 WP
DESCRIPTION	ELECTRICAL SECTION