

P-16053

S5048

X2090

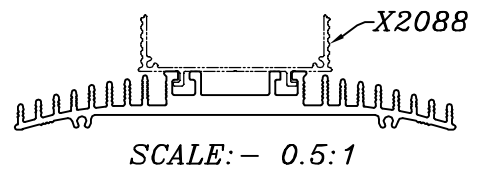
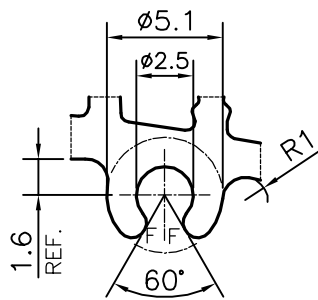
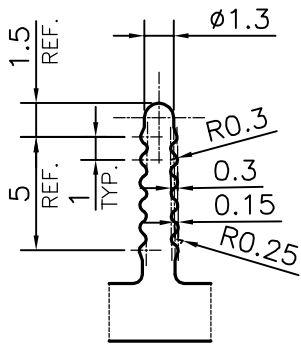
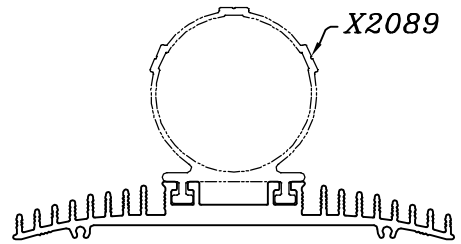
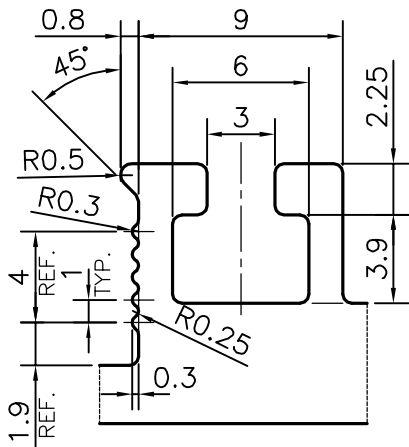
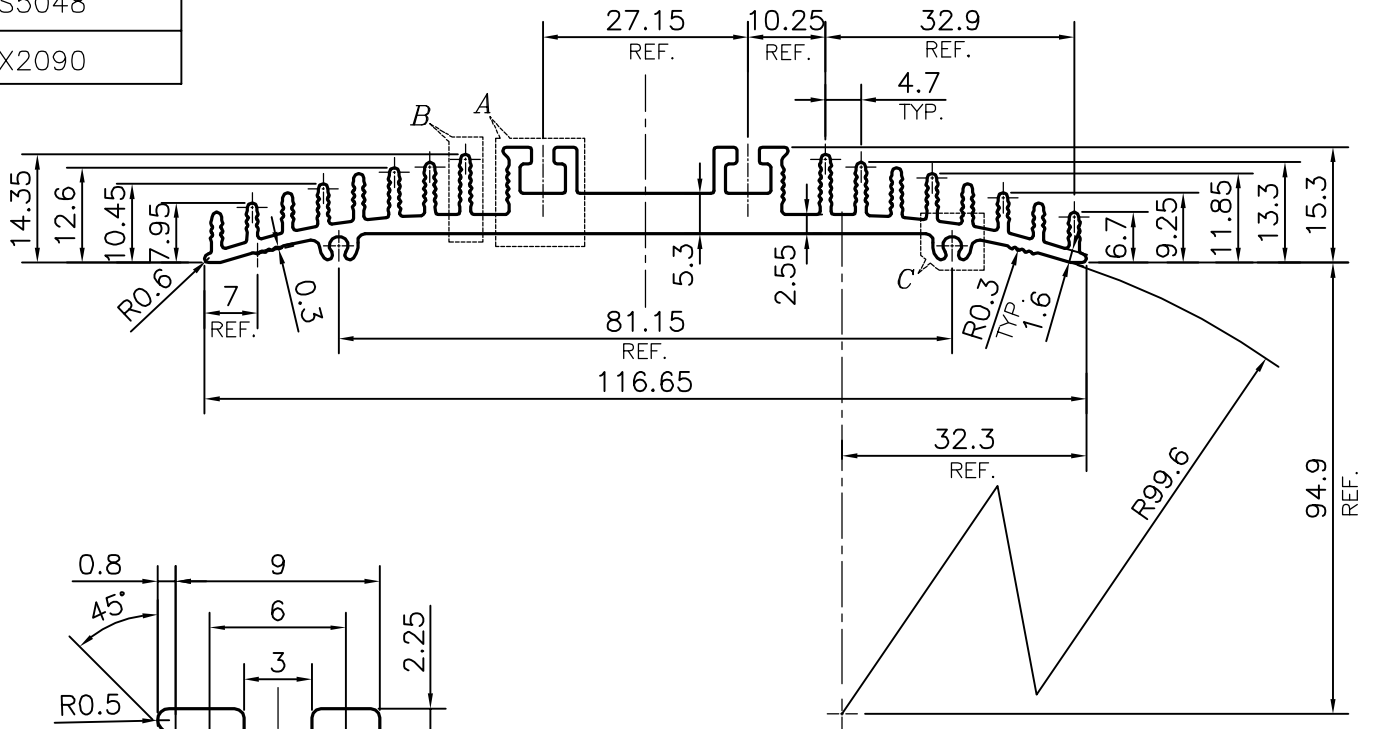

F = FULL RADIUS (4 PLACES)



SYMBOL OF QUALITY
AN ISO 9001 COMPANY

JINDAL ALUMINIUM LTD.
BANGALORE-560073 (INDIA)

	NAME	DATE
DRAWN	PARVESH	01-07-2016
CHECKED		
APPROVED	S.S. GARG	26-07-2016

1. ALL DIMENSIONS ARE IN mm.
2. ROUND OFF ALL SHARP CORNERS WITH 0.40 mm.
3. TOLERANCES WILL BE AS PER IS:3965-1981, UNLESS OTHERWISE SPECIFIED

SCALE	1:1
AREA mm ²	557.893
PERIMETER mm.	526.966
WEIGHT kg/m	1.506

PARTY'S NAME	VYOMA LITES, BANGALORE
PARTY'S DRAWING No.	AS PER AUTOCAD DRAWING-REQUIREMENT
ALLOY & TEMPER	HE9 WP
DESCRIPTION	HEAT SINK SECTION

DRAWING No.	SECTION No.
P-16053	-
S5048	S5048
X2090	X2090