

P-16085

S5049

X2091

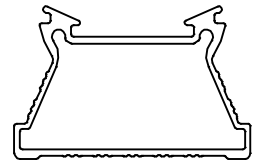

SCALE:- 1:1

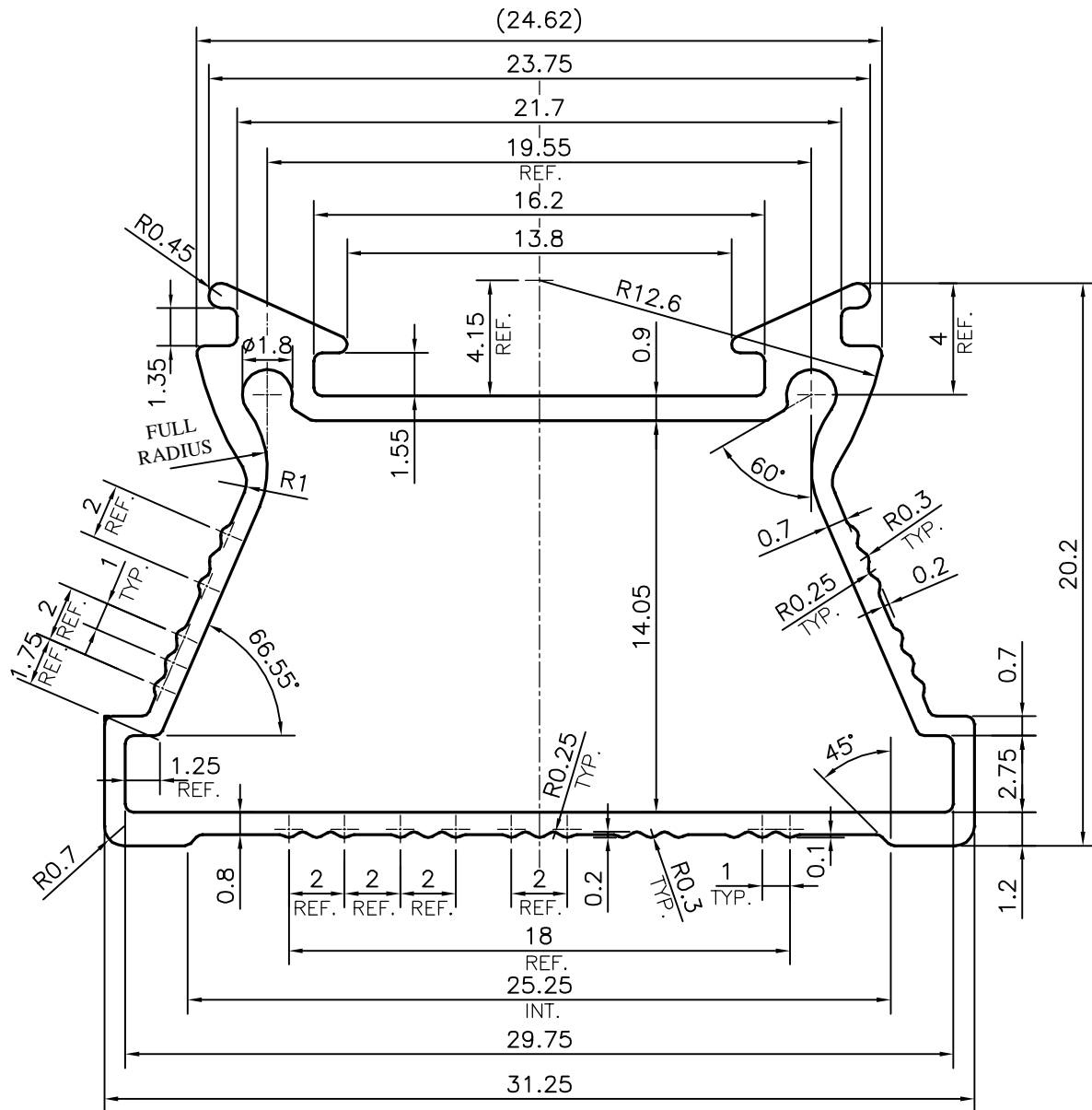

UNSPECIFIED CORNERS RADIUS WILL BE 0.30 mm.



SYMBOL OF QUALITY
AN ISO 9001 COMPANY

JINDAL ALUMINIUM LTD.
BANGALORE-560073 (INDIA)

	NAME	DATE
DRAWN	PARVESH	07-07-2016
CHECKED		
APPROVED	S.S. GARG	26-07-2016
SCALE		4:1
AREA mm ²		94.489
PERIMETER mm.		114.647
WEIGHT kg/m		0.255
DRAWING No.	SECTION No.	
P-16085	-	
S5049	S5049	
X2091	X2091	

1. ALL DIMENSIONS ARE IN mm.
2. ROUND OFF ALL SHARP CORNERS WITH 0.40 mm.
3. TOLERANCES WILL BE AS PER IS:6477-1983, UNLESS OTHERWISE SPECIFIED

PARTY'S NAME	VYOMA LITES, BANGALORE
PARTY'S DRAWING No.	AS PER AUTOCAD DRAWING-REQUIREMENT
ALLOY & TEMPER	HE9 WP
DESCRIPTION	TUBE LIGHT SECTION