

P-16087

S5051

X2093

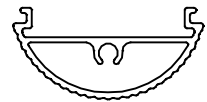

SCALE: - 1:1

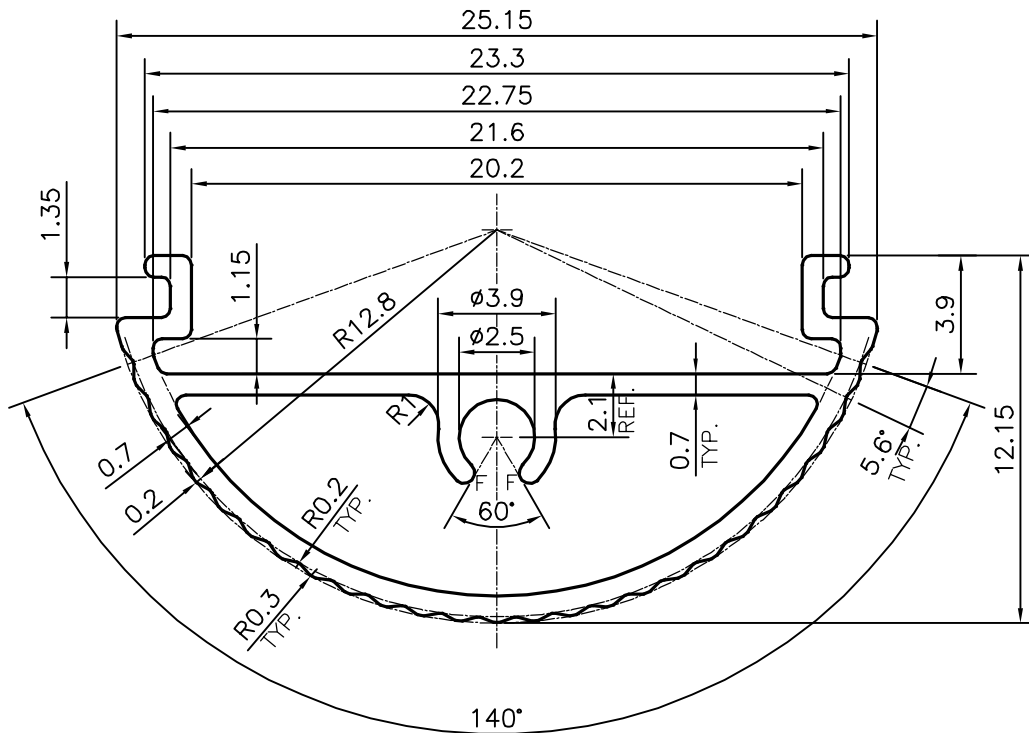

F = FULL RADIUS (2 PLACES)

**UNSPECIFIED CORNERS RADIUS WILL BE 0.30 mm.**



SYMBOL OF QUALITY  
AN ISO 9001 COMPANY

**JINDAL ALUMINIUM LTD.**  
BANGALORE-560073 (INDIA)

	NAME	DATE
DRAWN	PARVESH	07-07-2016
CHECKED		
APPROVED	S.S. GARG	26-07-2016
SCALE		4:1
AREA mm <sup>2</sup>		54.291
PERIMETER mm.		79.477
WEIGHT kg/m		0.147
DRAWING No.	SECTION No.	
P-16087	-	
S5051	S5051	
X2093	X2093	

1. ALL DIMENSIONS ARE IN mm.
2. ROUND OFF ALL SHARP CORNERS WITH 0.40 mm.
3. TOLERANCES WILL BE AS PER IS:6477-1983, UNLESS OTHERWISE SPECIFIED

PARTY'S NAME	VYOMA LITES, BANGALORE
PARTY'S DRAWING No.	AS PER AUTOCAD DRAWING-REQUIREMENT
ALLOY & TEMPER	HE9 WP
DESCRIPTION	TUBE LIGHT SECTION