

P-16031-1

X2102

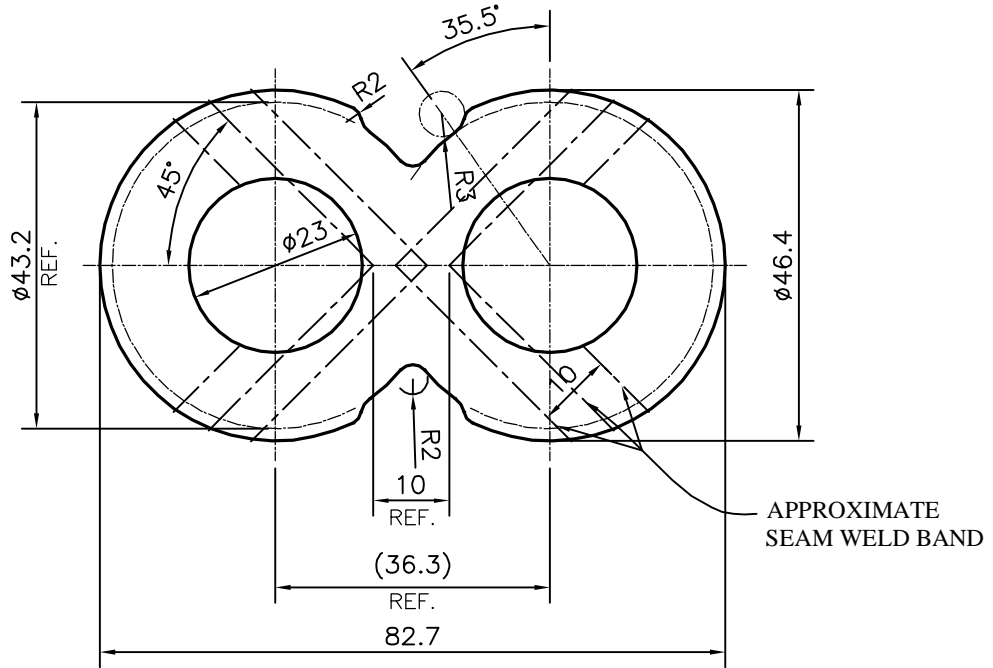

1. STRAIGHTNESS=1.5mm/M
2. TWIST=2.0mm/M
3. HARDNESS = 80 BHN



SYMBOL OF QUALITY
AN ISO 9001 COMPANY

JINDAL ALUMINIUM LTD.
BANGALORE-560073 (INDIA)

	NAME	DATE
DRAWN	PARVESH	16-07-2016
CHECKED		
APPROVED	B.NATARAJ	04-11-2016
SCALE		1:1
AREA mm ²		2295.783
PERIMETER mm.		233.846
WEIGHT kg/m		6.199
DRAWING No.	SECTION No.	
P-16031-1		
X2102	X2102	

1. ALL DIMENSIONS ARE IN mm.
2. ROUND OFF ALL SHARP CORNERS WITH 0.40 mm.
3. TOLERANCES WILL BE AS PER BS:EN-755-9, UNLESS OTHERWISE SPECIFIED

PARTY'S NAME	HEMA ENDUSTRI A.S., TURKEY
PARTY'S DRAWING No.	15P100004
ALLOY & TEMPER	6082 T6
DESCRIPTION	PUMP BODY SECTION