

P-17068

X2167

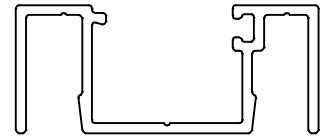

SCALE: - 1:1

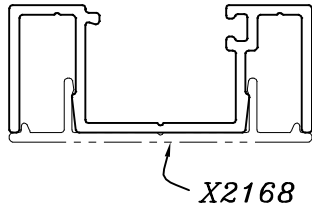
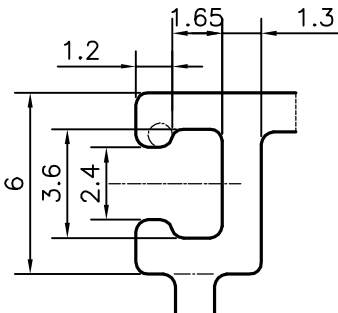
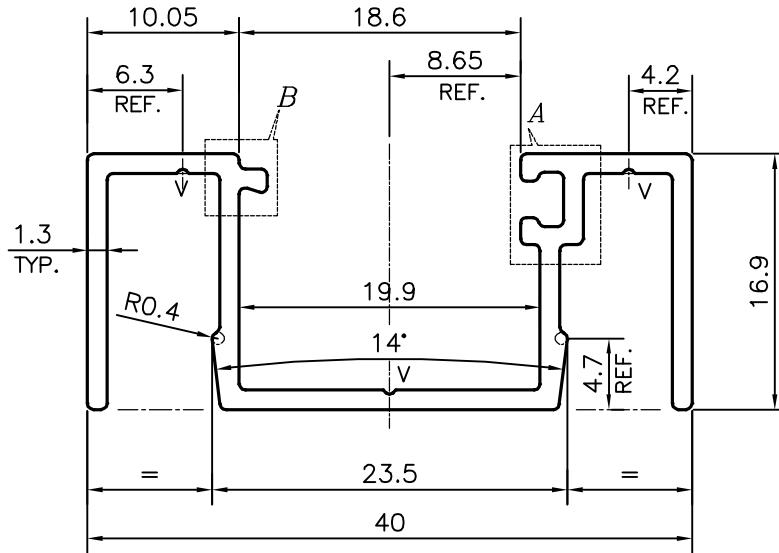

DETAIL OF "A"  
SCALE 4:1

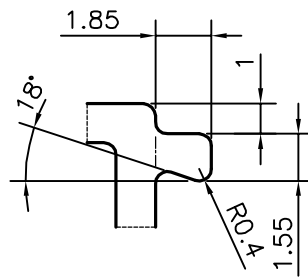

DETAIL OF "B"  
SCALE 4:1

V = VEE GROOVE 0.3x90° (3 PLACES)

TOLERANCES ON OVERALL WIDTHS & WIDTHS ACROSS FLATS OF BARS, & REGULAR SECTIONS

|                     |                      |                      |   |
|---------------------|----------------------|----------------------|---|
| UPTO 6.40mm - ±0.20 | UPTO 32.0mm - ±0.38  | UPTO 120.0mm - ±0.85 | 1. STRAIGHTNESS=1.7mm/M<br>2. TWIST=1.7mm/M<br>3. ANGULARITY= ±2°<br>4. FLATNESS =0.007xWIDTH |
| UPTO 10.0mm - ±0.23 | UPTO 50.0mm - ±0.46  | UPTO 160.0mm - ±1.02 |   |
| UPTO 12.0mm - ±0.25 | UPTO 60.0mm - ±0.53  | UPTO 200.0mm - ±1.14 |   |
| UPTO 16.0mm - ±0.28 | UPTO 80.0mm - ±0.69  | UPTO 250.0mm - ±1.40 |   |
| UPTO 25.0mm - ±0.30 | UPTO 100.0mm - ±0.75 | UPTO 300.0mm - ±1.65 |   |



SYMBOL OF QUALITY  
AN ISO 9001 COMPANY

**JINDAL ALUMINIUM LTD.**  
BANGALORE-560073 (INDIA)

|          |            |            |
|----------|------------|------------|
|          | NAME       | DATE       |
| DRAWN    | PARVESH    | 04-05-2017 |
| CHECKED  |            |            |
| APPROVED | B.NATARAJA | 16-05-2017 |

- ALL DIMENSIONS ARE IN mm.
- ROUND OFF ALL SHARP CORNERS WITH 0.40 mm.
- TOLERANCES WILL BE AS PER IS:3965-1981 , UNLESS OTHERWISE SPECIFIED

|                      |         |
|----------------------|---------|
| SCALE                | 2:1     |
| AREA mm <sup>2</sup> | 143.744 |
| PERIMETER mm.        | 217.79  |
| WEIGHT kg/m          | 0.388   |

|                     |   |
|---------------------|---|
| PARTY'S NAME        | TEAM WORK GLASS SOLUTIONS PVT LTD., HYDERABAD |
| PARTY'S DRAWING No. | SL-02   |
| ALLOY & TEMPER      | 6063 T6                                       |
| DESCRIPTION         | ARCHITECTURAL SECTION-VERTICAL FRAME          |

|             |             |
|-------------|-------------|
| DRAWING No. | SECTION No. |
| P-17068     | -           |
| X2167       | X2167       |