

P-17244

X2216

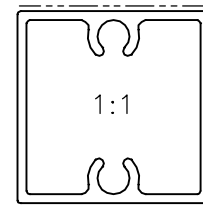

EXPOSED SURFACE

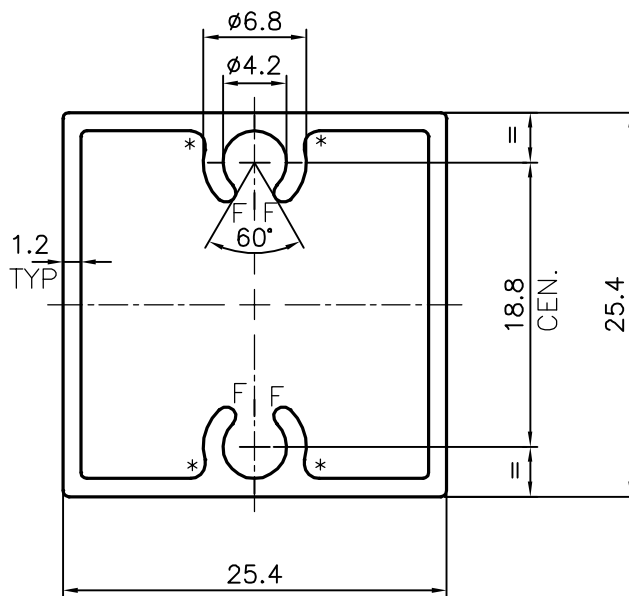

TOLERANCE CHART CD = CIRCUMSCRIBING CIRCLE

CD ≤ 100	100 < CD ≤ 200	200 < CD < 300	300 < CD < 500
UPTO 10mm - ±0.25	±0.30	±0.35	±0.40
10.0 - 25.0 - ±0.30	±0.40	±0.50	±0.60
25.0 - 50.0 - ±0.50	±0.60	±0.80	±0.90
50.0 - 100.0 - ±0.70	±0.90	±1.10	±1.30
100 - 150 - -	±1.10	±1.30	±1.50
150 - 200 - -	±1.3	±1.50	±1.80
200 - 300 - -	-	±1.70	±2.10
300 - 450 - -	-	-	±2.80

* = 1.0 RADIUS (4 PLACES)
 F = FULL RADIUS (4 PLACES)



SYMBOL OF QUALITY
 AN ISO 9001 COMPANY

JINDAL ALUMINIUM LTD.
 BANGALORE-560073 (INDIA)

	NAME	DATE
DRAWN	J.P.KAUSHIK	08-06-2017
CHECKED		
APPROVED	B.NATARAJA	16-06-2017
SCALE		2:1
AREA mm ²		145.132
PERIMETER mm.		100.913
WEIGHT kg/m		0.392
DRAWING No.	SECTION No.	
P-17244	-	
X2216	X2216	

1. ALL DIMENSIONS ARE IN mm.
2. ROUND OFF ALL SHARP CORNERS WITH 0.40 mm.
3. TOLERANCES WILL BE AS PER BS:EN-755-9 , UNLESS OTHERWISE SPECIFIED

PARTY'S NAME	A-1 ALUMINIUM INC, USA
PARTY'S DRAWING No.	KE 10656 STYLE F
ALLOY & TEMPER	6063 T5
DESCRIPTION	SQUARE TUBE-MISC.