

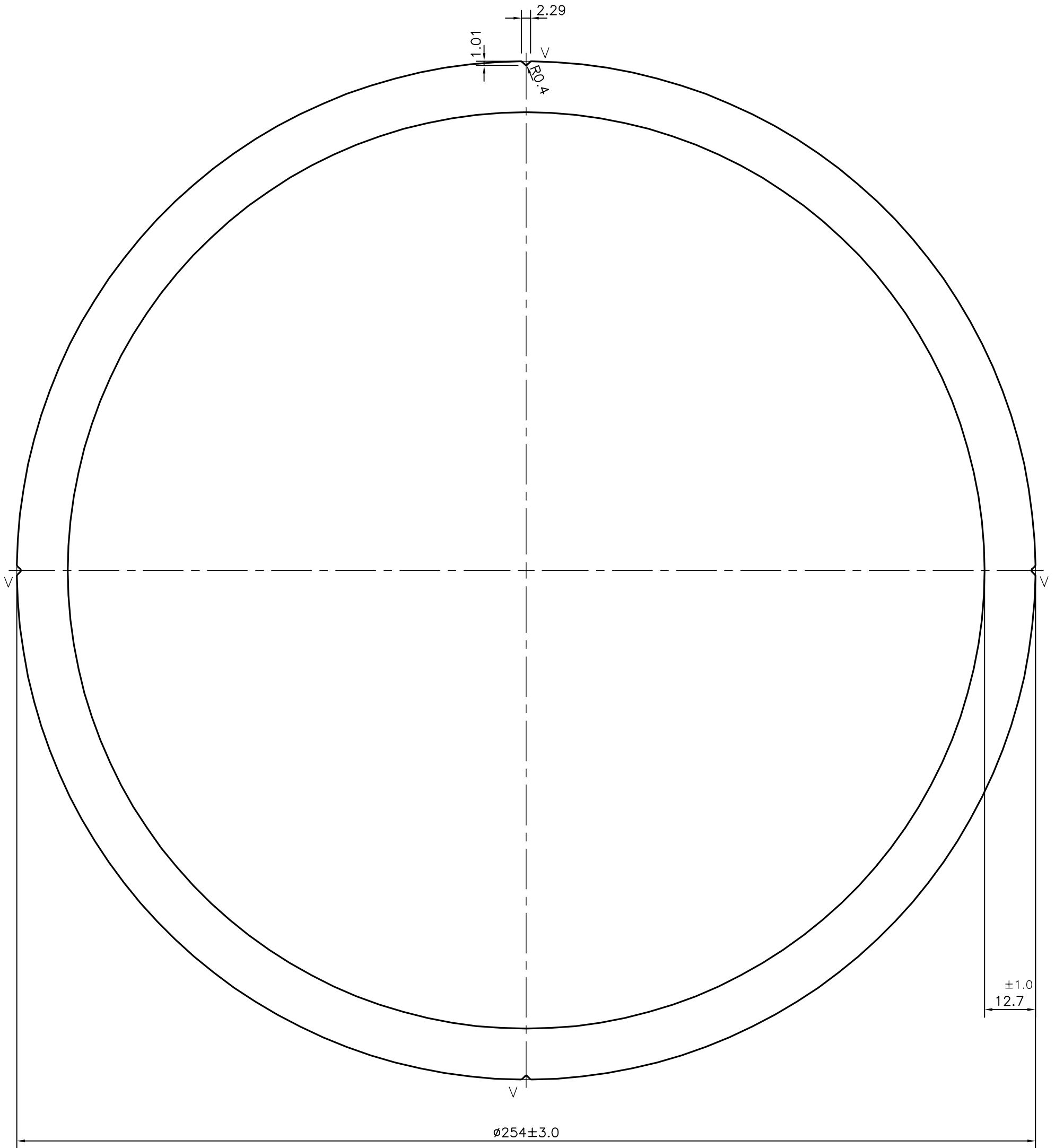

P-17319

X2232



∅254±3.0

V = V GROOVE (4 PLACES)

 SYMBOL OF QUALITY AN ISO 9001 COMPANY	<b>JINDAL ALUMINIUM LTD.</b> BANGALORE-560073 (INDIA)	NAME	DATE
		DRAWN	J.P.KAUSHIK 12-07-2017
1. ALL DIMENSIONS ARE IN mm. 2. ROUND OFF ALL SHARP CORNERS WITH 0.40 mm. 3. TOLERANCES WILL BE AS PER BS:EN-755-8 UNLESS OTHERWISE SPECIFIED		CHECKED	
		APPROVED	B.NATARAJA 31-07-2017
PARTY'S NAME CROWN ELECTRIC ENGINEERING & MANUFACTURING LLC, USA		SCALE	1:1
		AREA mm <sup>2</sup>	9622.128
PARTY'S DRAWING No. S-07-00010		PERIMETER mm.	801.066
		WEIGHT kg/m	25.980
ALLOY & TEMPER 1350 F		DRAWING No.	SECTION No.
		P-17319	-
DESCRIPTION ROUND TUBE MISC.-BUS DUCT CONDUCTOR 10"		X2232	X2232