

P-17580

X2270

245

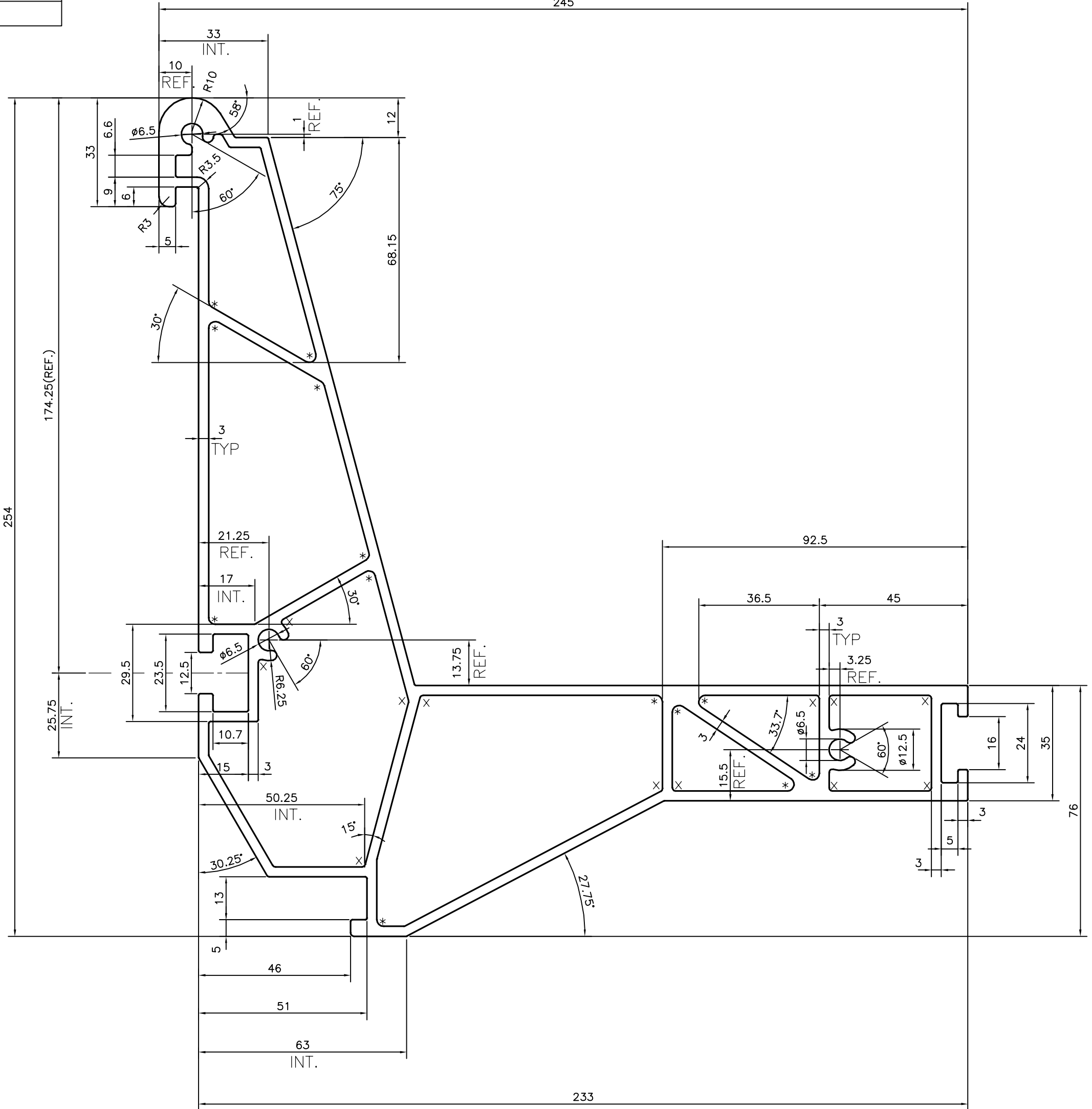

x = 1.0 RADIUS (11 PLACES)  
\* = 2.0 RADIUS (13 PLACES)

UNSPECIFIED RADIUS 0.5 mm

SCALE: - 1:4

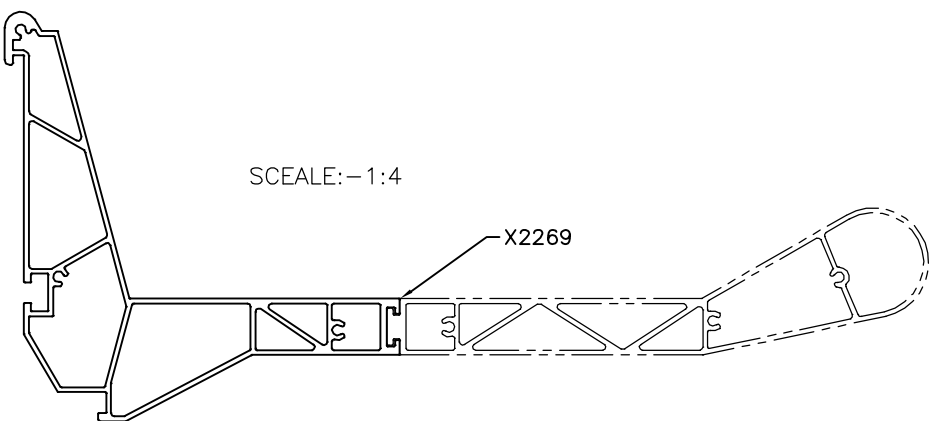

TOLERANCES ON OVERALL WIDTHS & WIDTHS ACROSS FLATS OF BARS, & REGULAR SECTIONS			
UPTO 6.40mm - ±0.20	UPTO 32.0mm - ±0.38	UPTO 120.0mm - ±0.85	UPTO 320.00mm - ±1.70
UPTO 10.0mm - ±0.23	UPTO 50.0mm - ±0.46	UPTO 160.0mm - ±1.02	
UPTO 12.0mm - ±0.25	UPTO 60.0mm - ±0.53	UPTO 200.0mm - ±1.14	
UPTO 16.0mm - ±0.28	UPTO 80.0mm - ±0.69	UPTO 250.0mm - ±1.40	
UPTO 25.0mm - ±0.30	UPTO 100.0mm - ±0.75	UPTO 300.0mm - ±1.65	

 SYMBOL OF QUALITY AN ISO 9001 COMPANY	<b>JINDAL ALUMINIUM LTD.</b> BANGALORE-560073 (INDIA)	NAME	DATE
		DRAWN	J.P.KAUSHIK 21-10-2017
1. ALL DIMENSIONS ARE IN mm. 2. ROUND OFF ALL SHARP CORNERS WITH 0.40 mm. 3. TOLERANCES WILL BE AS PER IS:6477-1983 UNLESS OTHERWISE SPECIFIED	PARTY'S NAME HANSPAL TRADERS, KAPURTHALA	CHECKED	
		APPROVED	B.NATARAJA 26-10-2017
		SCALE	1:1
		AREA mm <sup>2</sup>	3914.26
		PERIMETER mm.	1001.188
PARTY'S DRAWING No.	AS PER DRAWING	WEIGHT kg/m	10.569
ALLOY & TEMPER	63400 WP	DRAWING No.	
DESCRIPTION	RAIL COACH SECTION	SECTION No.	
		P-17580	-
		X2270	X2270