

P-17509-1

X2273

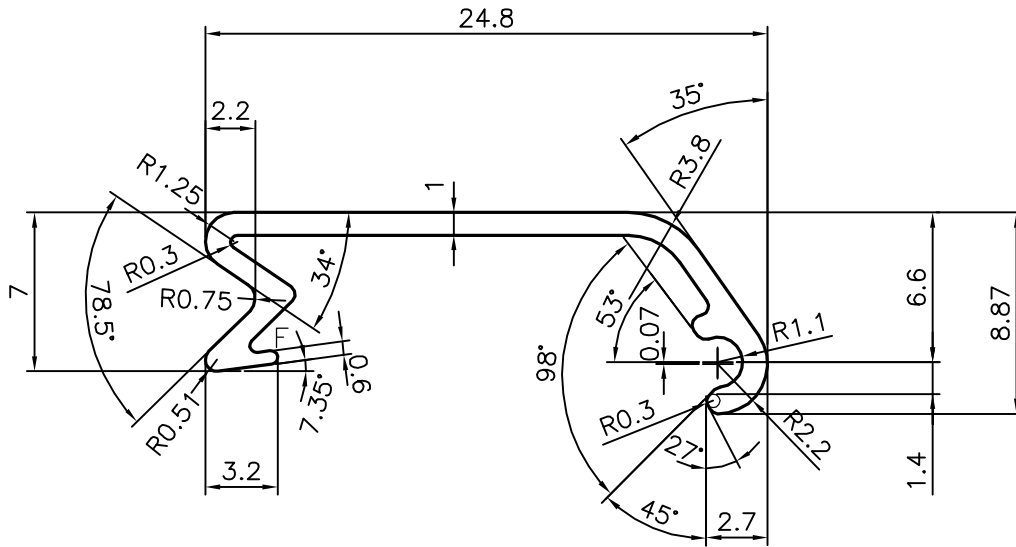

F = FULL RADIUS (ONE PLACE)

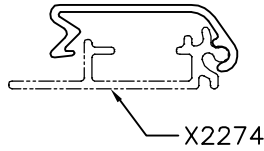

SYMBOL OF QUALITY
AN ISO 9002 COMPANY

JINDAL ALUMINIUM LTD.
BANGALORE-560073 (INDIA)

	NAME	DATE
DRAWN	J.P.KAUSHIK	30-10-2017
CHECKED		
APPROVED	B.NATARAJA	11-11-2017
SCALE		3:1
AREA mm ²		42.277
PERIMETER mm.		82.163
WEIGHT kg/m		0.114
DRAWING No.	SECTION No.	
P-17509-1	-	
X2273	X2273	

1. ALL DIMENSIONS ARE IN mm.
2. ROUND OFF ALL SHARP CORNERS WITH 0.40 mm.
3. TOLERANCES WILL BE AS PER BS:EN-755-9 , UNLESS OTHERWISE SPECIFIED

PARTY'S NAME	DISPLAY MANIA INTERNATIONAL, SOUTH AFRICA
PARTY'S DRAWING No.	AC27328
ALLOY & TEMPER	6063 T6
DESCRIPTION	DISPLAY SECTION