

P-17511-1

X2275

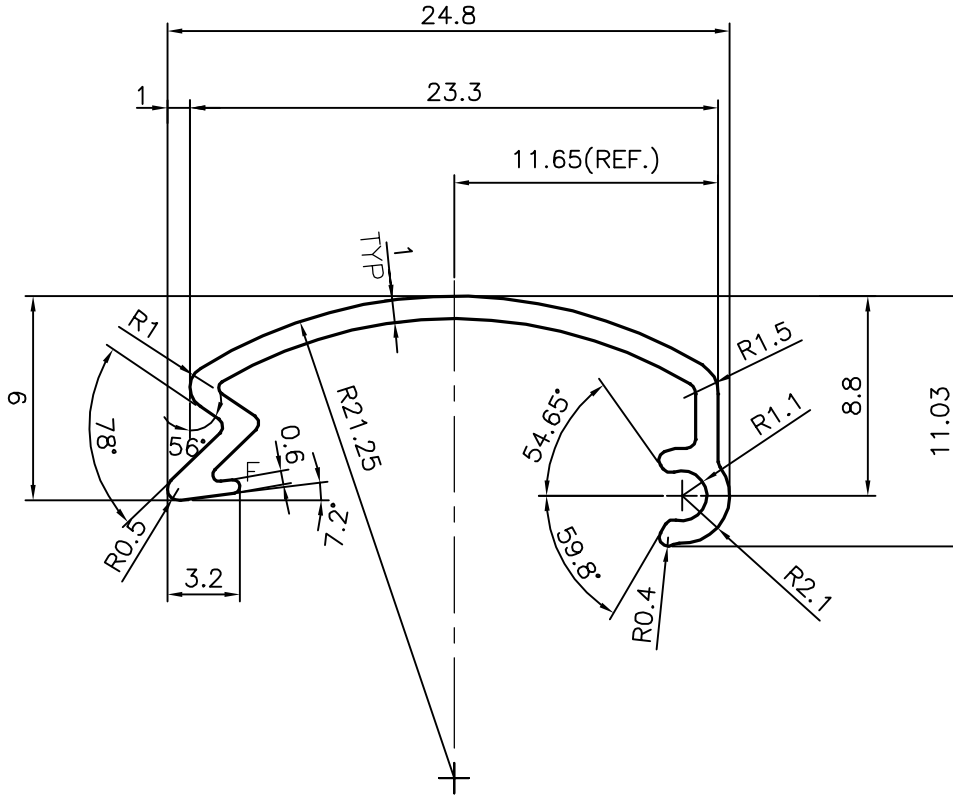

F = FULL RADIUS (ONE PLACE)

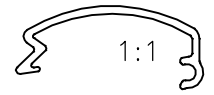

SYMBOL OF QUALITY
AN ISO 9002 COMPANY

JINDAL ALUMINIUM LTD.
BANGALORE-560073 (INDIA)

	NAME	DATE
DRAWN	J.P.KAUSHIK	30-10-2017
CHECKED		
APPROVED	B.NATARAJA	11-11-2017
SCALE		3:1
AREA mm ²		42.493
PERIMETER mm.		84.706
WEIGHT kg/m		0.115

1. ALL DIMENSIONS ARE IN mm.
2. ROUND OFF ALL SHARP CORNERS WITH 0.40 mm.
3. TOLERANCES WILL BE AS PER BS:EN-755-9 , UNLESS OTHERWISE SPECIFIED

PARTY'S NAME	DISPLAY MANIA INTERNATIONAL, SOUTH AFRICA	DRAWING No.	P-17511-1	SECTION No.	-
PARTY'S DRAWING No.	AC32540/2		X2275		X2275
ALLOY & TEMPER	6063 T6				
DESCRIPTION	DISPLAY SECTION				