

P-17670

X2282

X2283

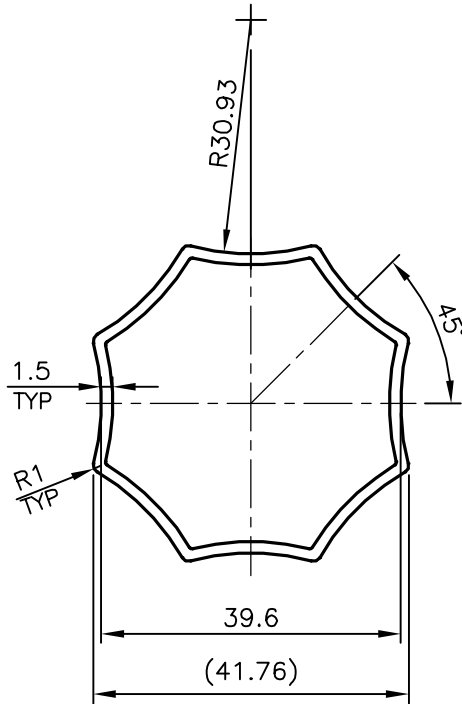
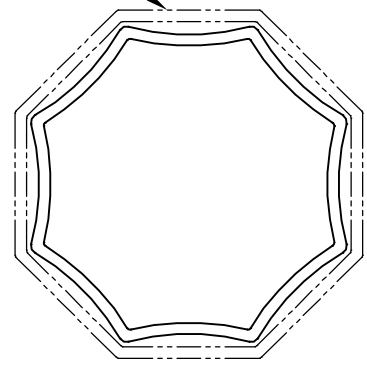

SYMBOL OF QUALITY
AN ISO 9001 COMPANY

JINDAL ALUMINIUM LTD.
BANGALORE-560073 (INDIA)

	NAME	DATE
DRAWN	J.P.KAUSHIK	25-11-2017
CHECKED		
APPROVED	B.NATARAJA	01-12-2017
SCALE		1:1
AREA mm ²		202.157
PERIMETER mm.		139.543
WEIGHT kg/m		0.546
DRAWING No.	SECTION No.	
P-17670	-	
X2282	X2282	

1. ALL DIMENSIONS ARE IN mm.
2. ROUND OFF ALL SHARP CORNERS WITH 0.40 mm.
3. TOLERANCES WILL BE AS PER BS:EN-755-9 UNLESS OTHERWISE SPECIFIED

PARTY'S NAME	NATIONAL DAIRY EQUIPMENTS (NDE), SOUTH AFRICA
PARTY'S DRAWING No.	AS PER DRAWING
ALLOY & TEMPER	6063 T6
DESCRIPTION	OCTAGONAL TUBE-MISC.