

P-17790

X2290

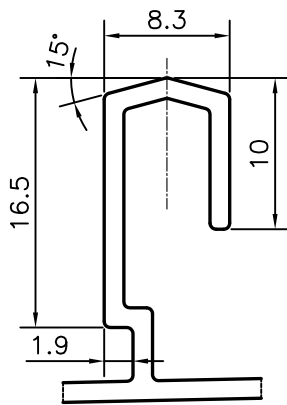
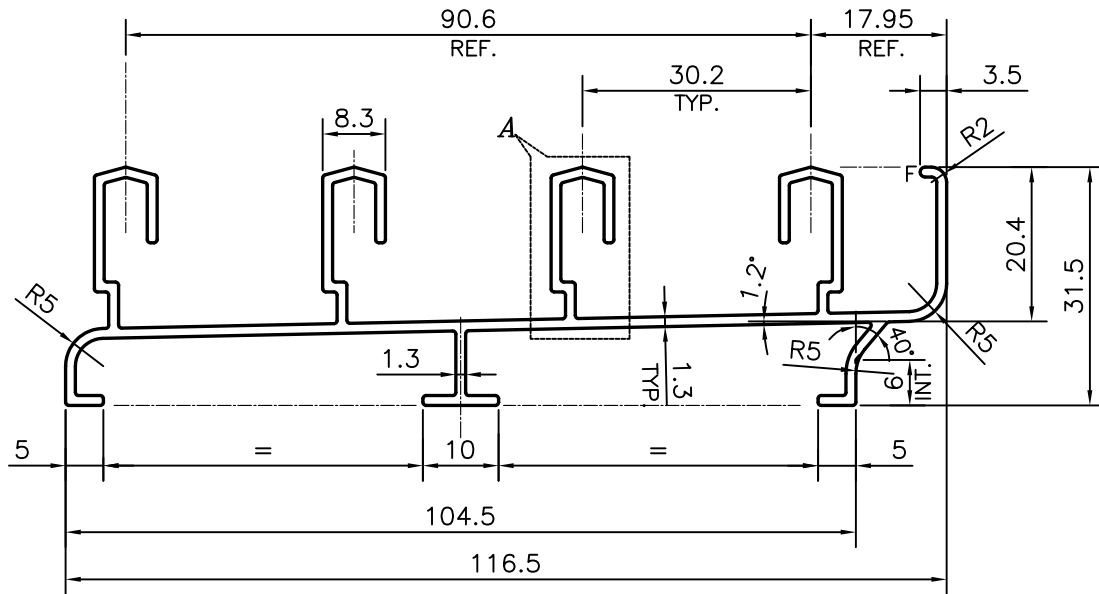

DETAIL OF "A"
SCALE 2:1

F = FULL RADIUS (1 PLACE)



SYMBOL OF QUALITY
AN ISO 9001 COMPANY

JINDAL ALUMINIUM LTD.
BANGALORE-560073 (INDIA)

	NAME	DATE
DRAWN	PARVESH	16-01-2018
CHECKED		
APPROVED	B.NATARAJA	23-01-2018
SCALE		1:1
AREA	mm ²	423.417
PERIMETER	mm.	642.65
WEIGHT	kg/m	1.143
DRAWING No.	SECTION No.	
P-17790	-	
X2290	X2290	

1. ALL DIMENSIONS ARE IN mm.
2. ROUND OFF ALL SHARP CORNERS WITH 0.4 mm.
3. TOLERANCES WILL BE AS PER IS:3965-1981 , UNLESS OTHERWISE SPECIFIED

PARTY'S NAME	MAHARASHTRA ALUMINIUM CENTRE, MUMBAI
PARTY'S DRAWING No.	AS PER DRAWING
ALLOY & TEMPER	HE9 WP
DESCRIPTION	WINDOW SECTION