

P-17794

X2294

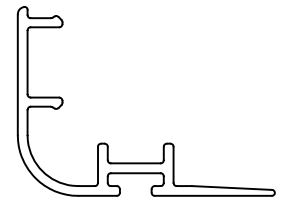

SCALE: - 1:1

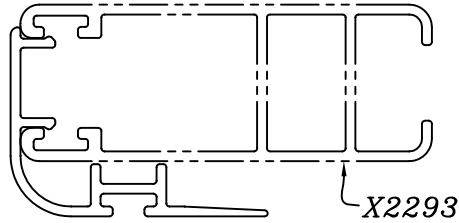
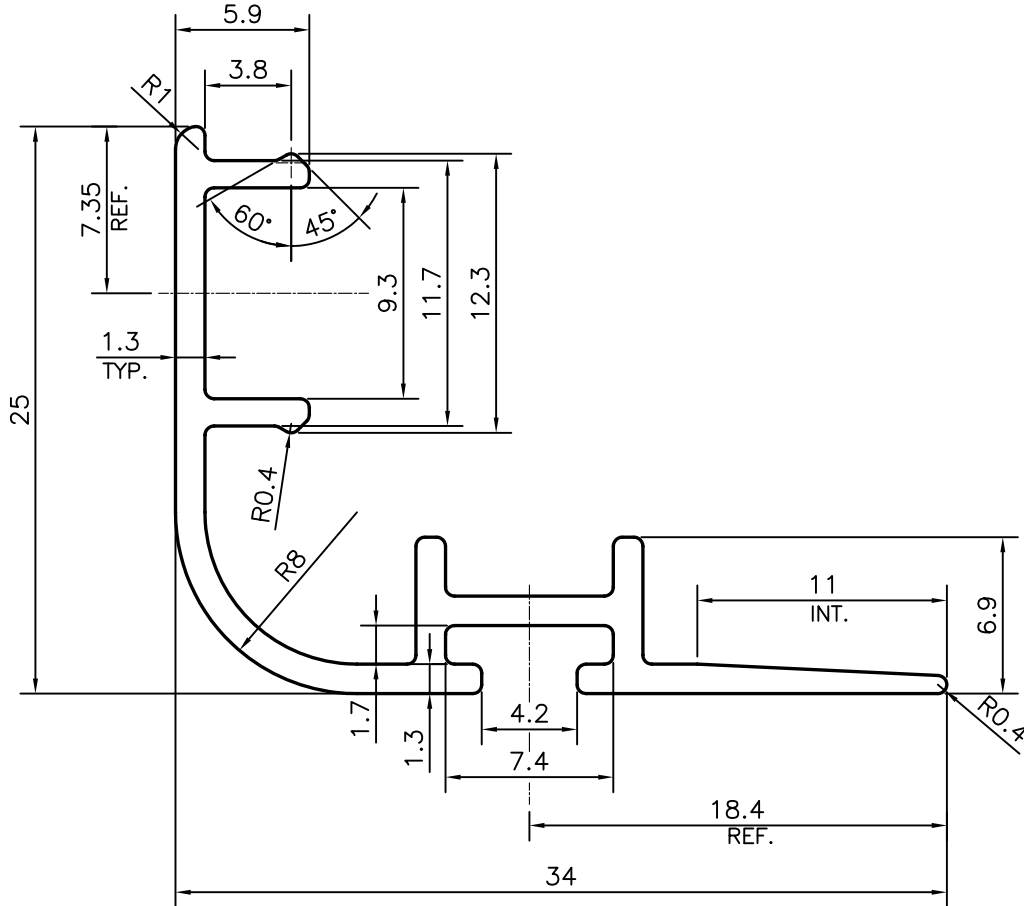

SYMBOL OF QUALITY  
AN ISO 9001 COMPANY

**JINDAL ALUMINIUM LTD.**  
BANGALORE-560073 (INDIA)

	NAME	DATE
DRAWN	PARVESH	17-01-2018
CHECKED		
APPROVED	B.NATARAJA	23-01-2018

1. ALL DIMENSIONS ARE IN mm.
2. ROUND OFF ALL SHARP CORNERS WITH 0.4 mm.
3. TOLERANCES WILL BE AS PER IS:3965-1981 , UNLESS OTHERWISE SPECIFIED

SCALE	3:1
AREA mm <sup>2</sup>	97.864
PERIMETER mm.	153.618
WEIGHT kg/m	0.264

PARTY'S NAME	MAHARASHTRA ALUMINIUM CENTRE, MUMBAI	DRAWING No.	P-17794	SECTION No.	-
PARTY'S DRAWING No.	AS PER DRAWING		X2294		X2294
ALLOY & TEMPER	HE9 WP				
DESCRIPTION	GLAZING CLIP SECTION				