

P-17825

X2299

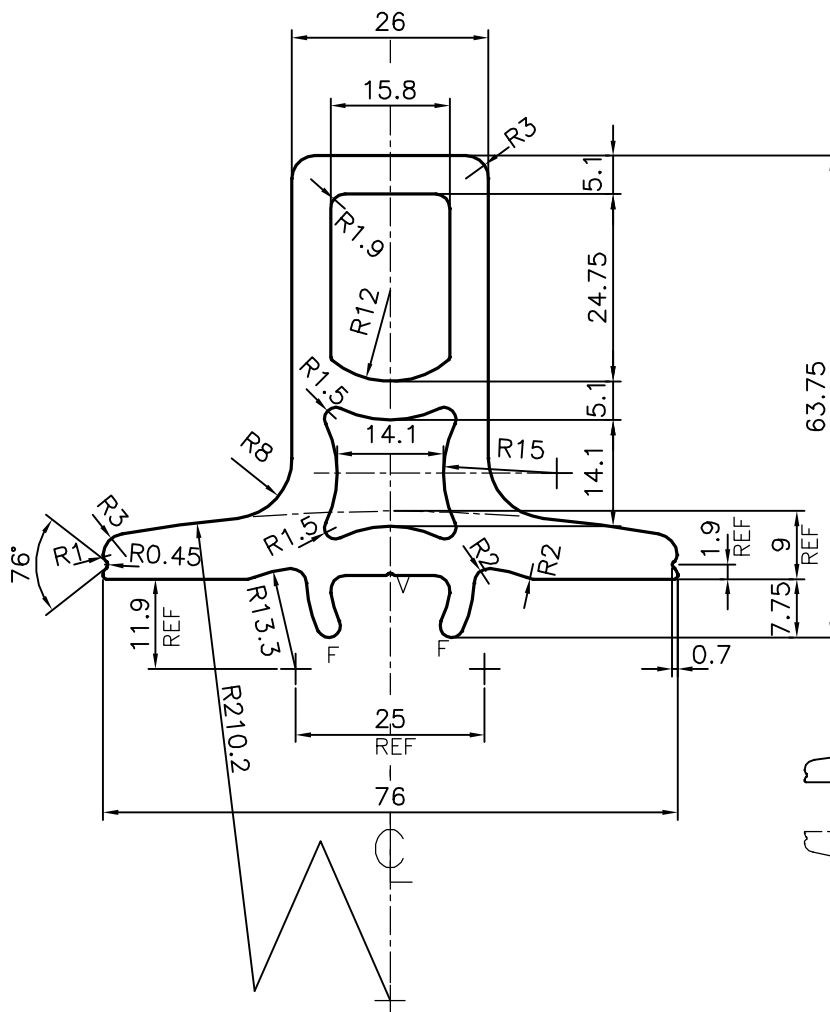

SCALE:- 1:2

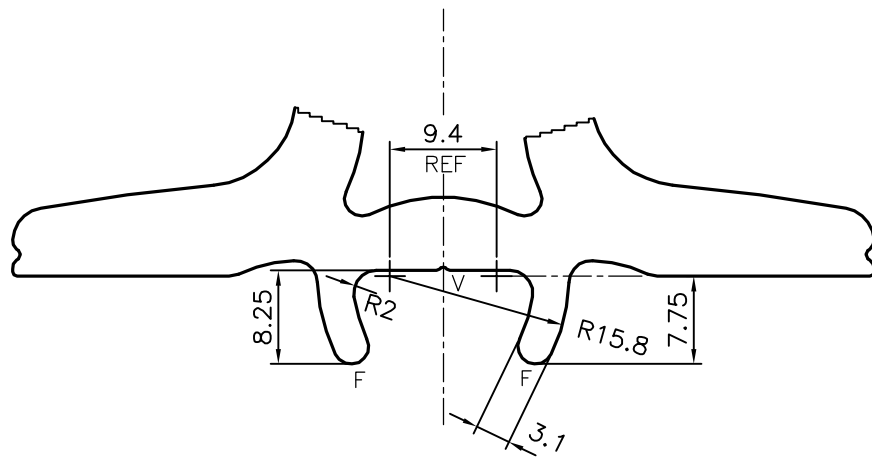
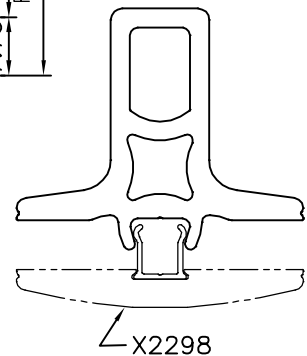

V = V GROOVE 0.3x90° (ONE PLACE)



SYMBOL OF QUALITY
AN ISO 9001 COMPANY

JINDAL ALUMINIUM LTD.
BANGALORE-560073 (INDIA)

	NAME	DATE
DRAWN	J.P.KAUSHIK	31-01-2018
CHECKED		
APPROVED	B.NATARAJ	15-02-2018
SCALE		1:1
AREA mm ²		1249.607
PERIMETER mm.		278.874
WEIGHT kg/m		3.374
DRAWING No.	SECTION No.	
P-17825	-	
X2299	X2299	

1. ALL DIMENSIONS ARE IN mm.
2. ROUND OFF ALL SHARP CORNERS WITH 0.40 mm.
3. TOLERANCES WILL BE AS PER BS:EN-755-9, UNLESS OTHERWISE SPECIFIED

PARTY'S NAME	PROSOURCE INDL. SOLUTIONS INC., CANADA
PARTY'S DRAWING No.	AS PER DRAWING
ALLOY & TEMPER	6063 T5
DESCRIPTION	MISC. SECTION