

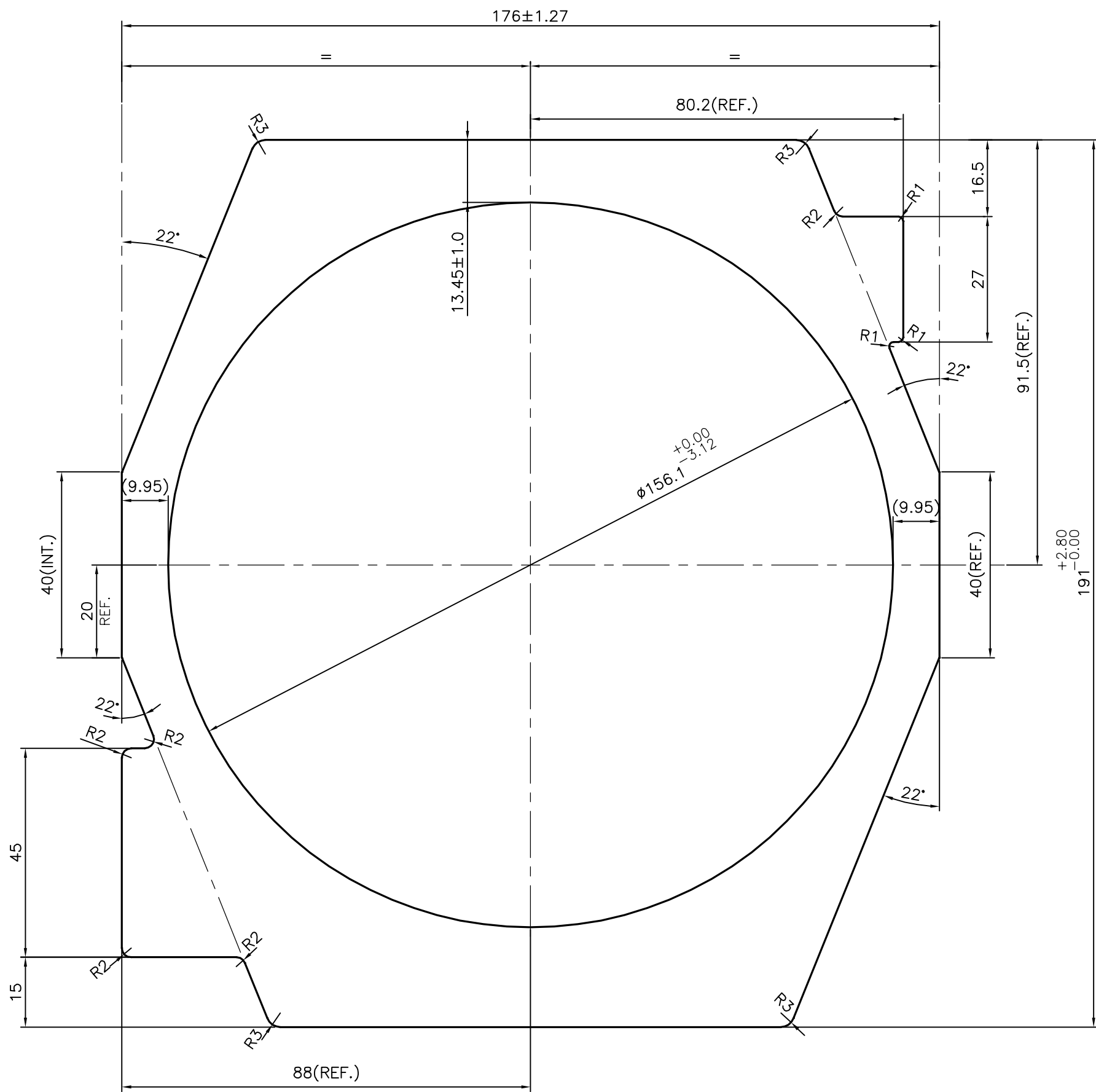

P-17781-2

X2320



 SYMBOL OF QUALITY AN ISO 9001 COMPANY	<b>JINDAL ALUMINIUM LTD.</b> BANGALORE-560073 (INDIA)	DRAWN	J.P.KAUSHIK	26-03-2018
		CHECKED		
1. ALL DIMENSIONS ARE IN mm. 2. ROUND OFF ALL SHARP CORNERS WITH 0.40 mm. 3. TOLERANCES WILL BE AS PER IS:6477-1983 UNLESS OTHERWISE SPECIFIED		APPROVED	<b>B.NATARAJA</b>	28-03-2018
		SCALE		1:1
PARTY'S NAME ROTEX MANUFACTURERS & ENGINEERS PVT. LTD., THANE		AREA	mm <sup>2</sup>	10864.412
		PERIMETER	mm.	673.71
PARTY'S DRAWING No. 12-60-109-08C REV. 9		WEIGHT	kg/m	29.334
		DRAWING No.		SECTION No.
ALLOY & TEMPER 6063 T6		P-17781-2		-
		X2320		X2320
DESCRIPTION PUMP BODY SECTION				