

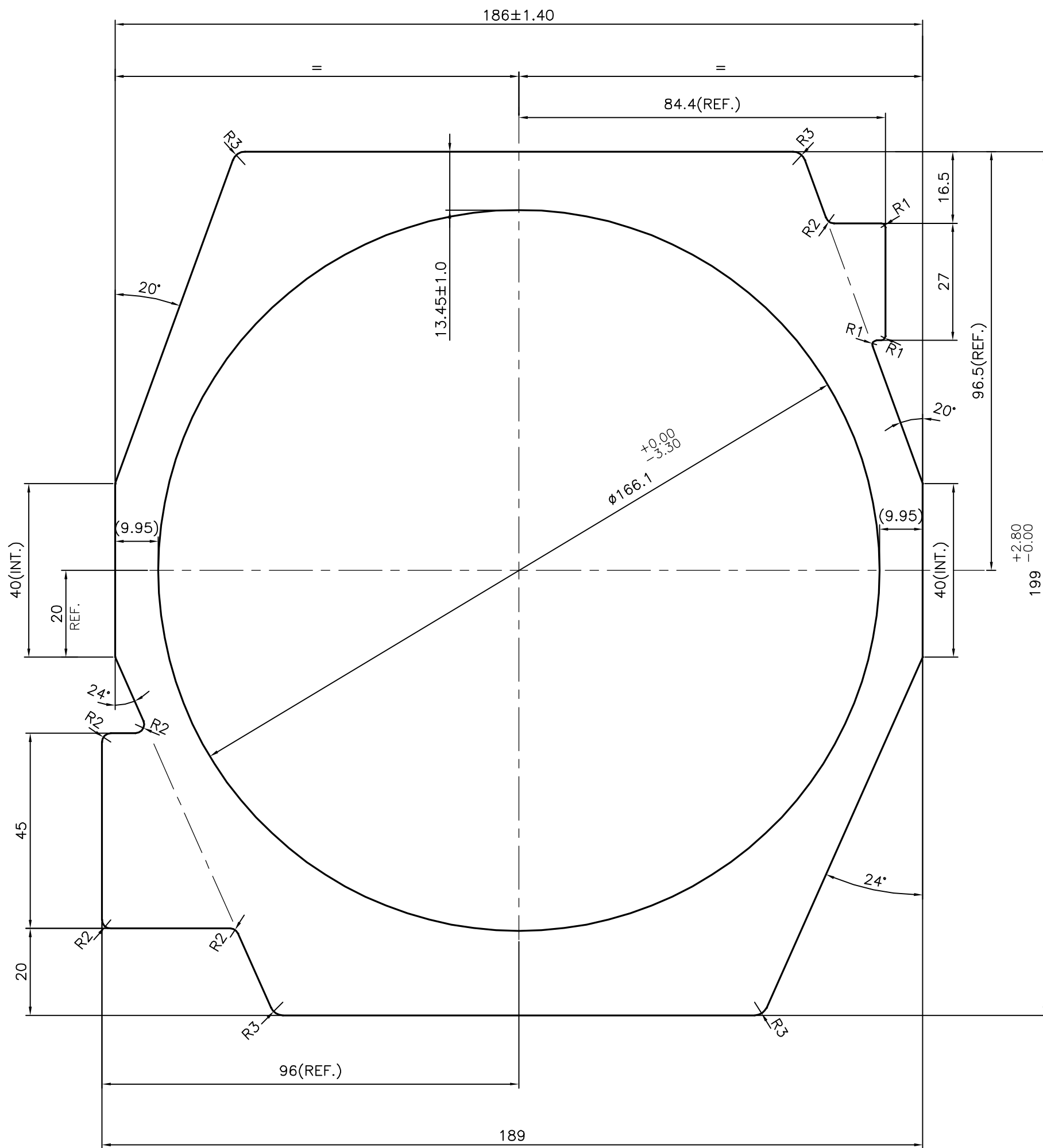

P-17782-2

X2321



 SYMBOL OF QUALITY AN ISO 9001 COMPANY	<b>JINDAL ALUMINIUM LTD.</b> BANGALORE-560073 (INDIA)	NAME	DATE
		DRAWN	J.P.KAUSHIK 26-03-2018
1. ALL DIMENSIONS ARE IN mm. 2. ROUND OFF ALL SHARP CORNERS WITH 0.40 mm. 3. TOLERANCES WILL BE AS PER IS:6477-1983 UNLESS OTHERWISE SPECIFIED		CHECKED	
		APPROVED	B.NATARAJA 28-03-2018
PARTY'S NAME ROTEX MANUFACTURERS & ENGINEERS PVT. LTD., THANE		SCALE	1:1
		AREA mm <sup>2</sup>	11344.501
PARTY'S DRAWING No. 12-60-110-01C REV. 15		PERIMETER mm.	710.258
		WEIGHT kg/m	30.630
ALLOY & TEMPER 6063 T6		DRAWING No.	SECTION No.
		P-17782-2	-
DESCRIPTION PUMP BODY SECTION		X2321	X2321