

P-18028

X2330

EXPOSED SURFACE

1:1

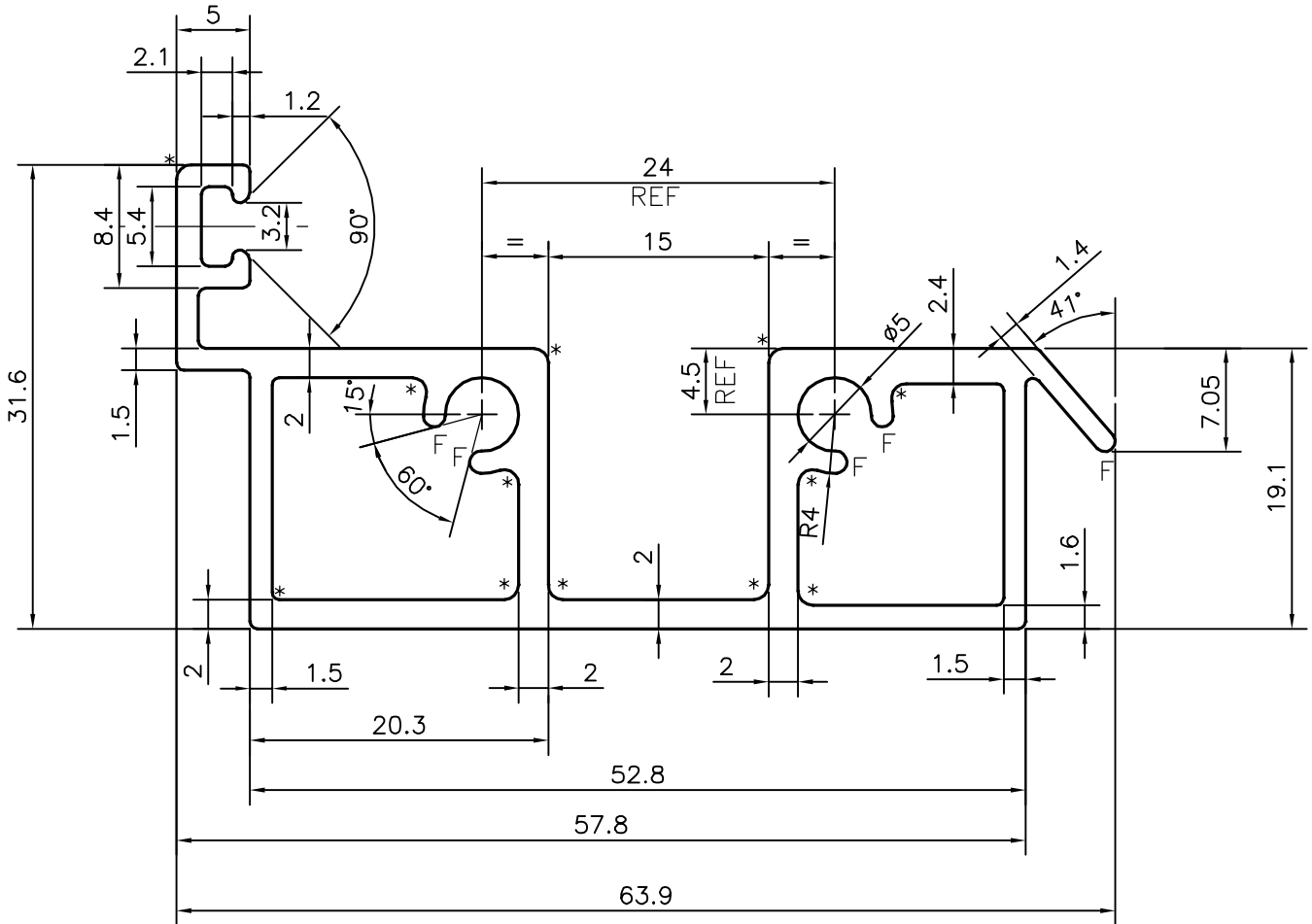

UNSPECIFIED RADIUS 0.5 mm

* = 1.0 RADIUS (12 PLACES)
F = FULL RADIUS (5 PLACES)



SYMBOL OF QUALITY
AN ISO 9001 COMPANY

JINDAL ALUMINIUM LTD.
BANGALORE-560073 (INDIA)

	NAME	DATE
DRAWN	J.P.KAUSHIK	23-03-2018
CHECKED		
APPROVED	B.NATARAJA	07-04-2018
SCALE		2:1
AREA mm ²		363.936
PERIMETER mm.		240.729
WEIGHT kg/m		0.983
DRAWING No.	SECTION No.	
P-18028	-	
X2330	X2330	

1. ALL DIMENSIONS ARE IN mm.
2. ROUND OFF ALL SHARP CORNERS WITH 0.40 mm.
3. TOLERANCES WILL BE AS PER IS:6477-1983, UNLESS OTHERWISE SPECIFIED

PARTY'S NAME	AMBICA ALUMINIUM CO., BANGALORE
PARTY'S DRAWING No.	AS PER DRAWING
ALLOY & TEMPER	6060 T6
DESCRIPTION	FRAME BOTTOM