

P-16318

X2342

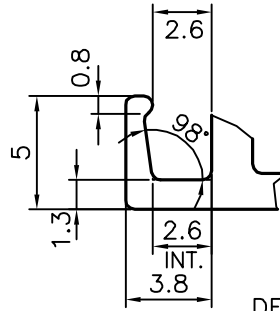

DETAIL OF "A"
SCALE 3:1

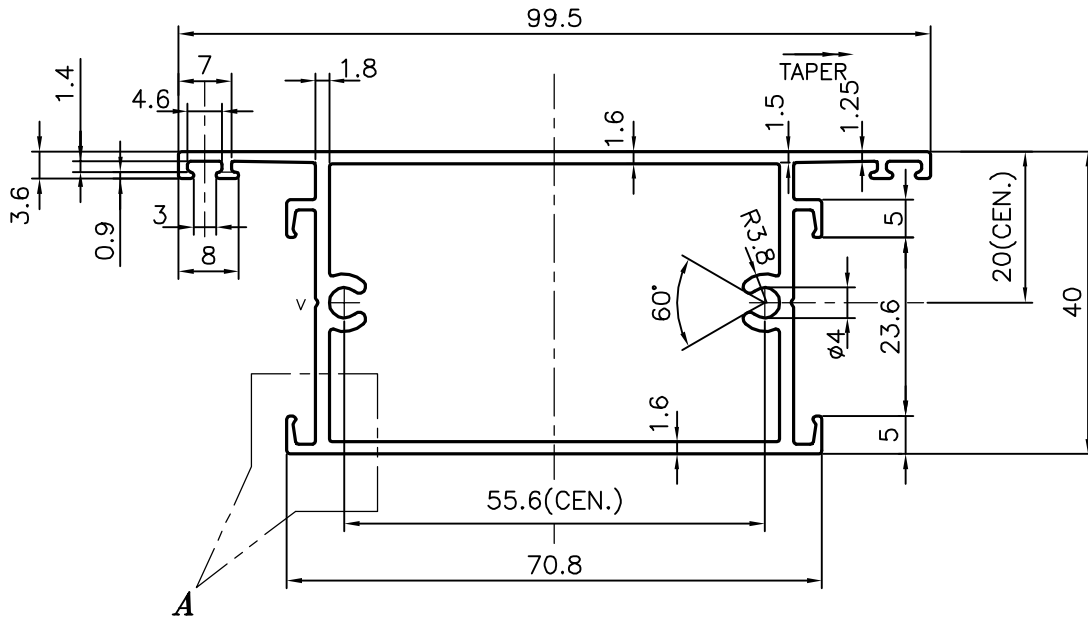

V = V GROOVE 0.3x90° (2 PLACE)



SYMBOL OF QUALITY
AN ISO 9001 COMPANY

JINDAL ALUMINIUM LTD.
BANGALORE-560073 (INDIA)

	NAME	DATE
DRAWN	J.P.KAUSHIK	15-09-2016
CHECKED		
APPROVED	B.NATARAJA	14-05-2018

1. ALL DIMENSIONS ARE IN mm.
2. ROUND OFF ALL SHARP CORNERS WITH 0.40 mm.
3. TOLERANCES WILL BE AS PER IS:6477-1983 UNLESS OTHERWISE SPECIFIED

SCALE	1:1
AREA mm ²	471.079
PERIMETER mm.	359.667
WEIGHT kg/m	1.272

PARTY'S NAME	AMBICA ALUMINIUM COMPANY, BANGALORE
PARTY'S DRAWING No.	AS PER AutoCAD DRAWING-GT/NCCL/ND/004/8
ALLOY & TEMPER	HE9 WP
DESCRIPTION	WINDOW SECTION

DRAWING No.	SECTION No.
P-16318	-
X2342	X2342