

P-18297

X2354

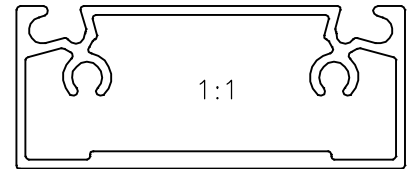

1:1

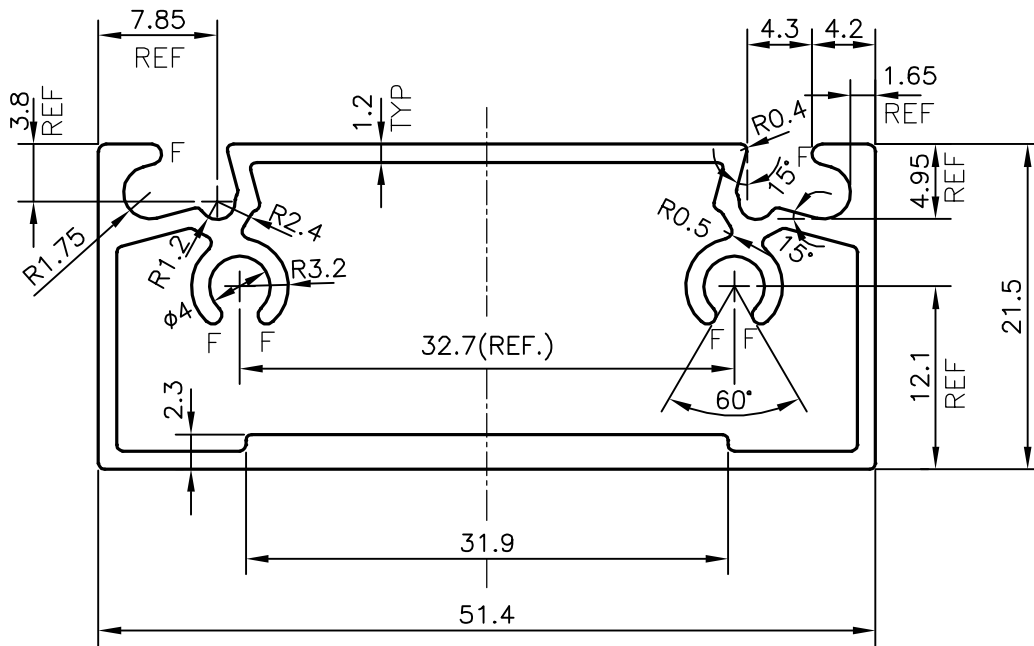

F = FULL RADIUS(8 PLACES)



SYMBOL OF QUALITY
AN ISO 9001 COMPANY

JINDAL ALUMINIUM LTD.
BANGALORE-560073 (INDIA)

	NAME	DATE
DRAWN	J.P.KAUSHIK	06-06-2018
CHECKED		
APPROVED	B.NATARAJA	02-07-2018
SCALE		2:1
AREA mm ²		266.689
PERIMETER mm.		171.529
WEIGHT kg/m		0.720
DRAWING No.	SECTION No.	
P-18297	-	
X2354	X2354	

1. ALL DIMENSIONS ARE IN mm.
2. ROUND OFF ALL SHARP CORNERS WITH 0.40 mm.
3. TOLERANCES WILL BE AS PER BS:EN-755-9 , UNLESS OTHERWISE SPECIFIED

PARTY'S NAME	A-1 ALUMINIUM INC., USA
PARTY'S DRAWING No.	11A243B1
ALLOY & TEMPER	6063 T6
DESCRIPTION	TOP MIDDLE RAIL SCREEN DOOR