

P-18287-4

X2359

TOLERANCE CHART CD = CIRCUMSCRIBING CIRCLE

DIMENSION	CD ≤ 100	100 < CD ≤ 200	200 < CD ≤ 300	300 < CD ≤ 500
UPTO 10mm	±0.25	±0.30	±0.35	±0.40
10.0 - 25.0	±0.30	±0.40	±0.50	±0.60
25.0 - 50.0	±0.50	±0.60	±0.80	±0.90
50.0 - 100	±0.70	±0.90	±1.10	±1.30
100 - 150	-	±1.10	±1.30	±1.50
150 - 200	-	±1.3	±1.50	±1.80
200 - 300	-	-	±1.70	±2.10
300 - 450	-	-	-	±2.80

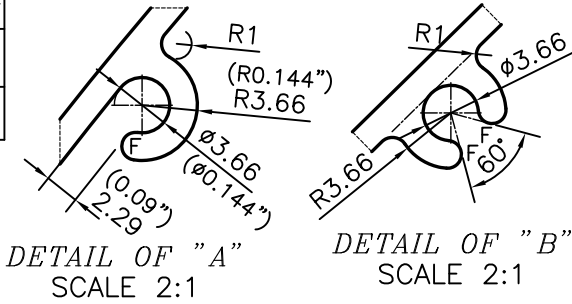

EXPOSED SURFACE

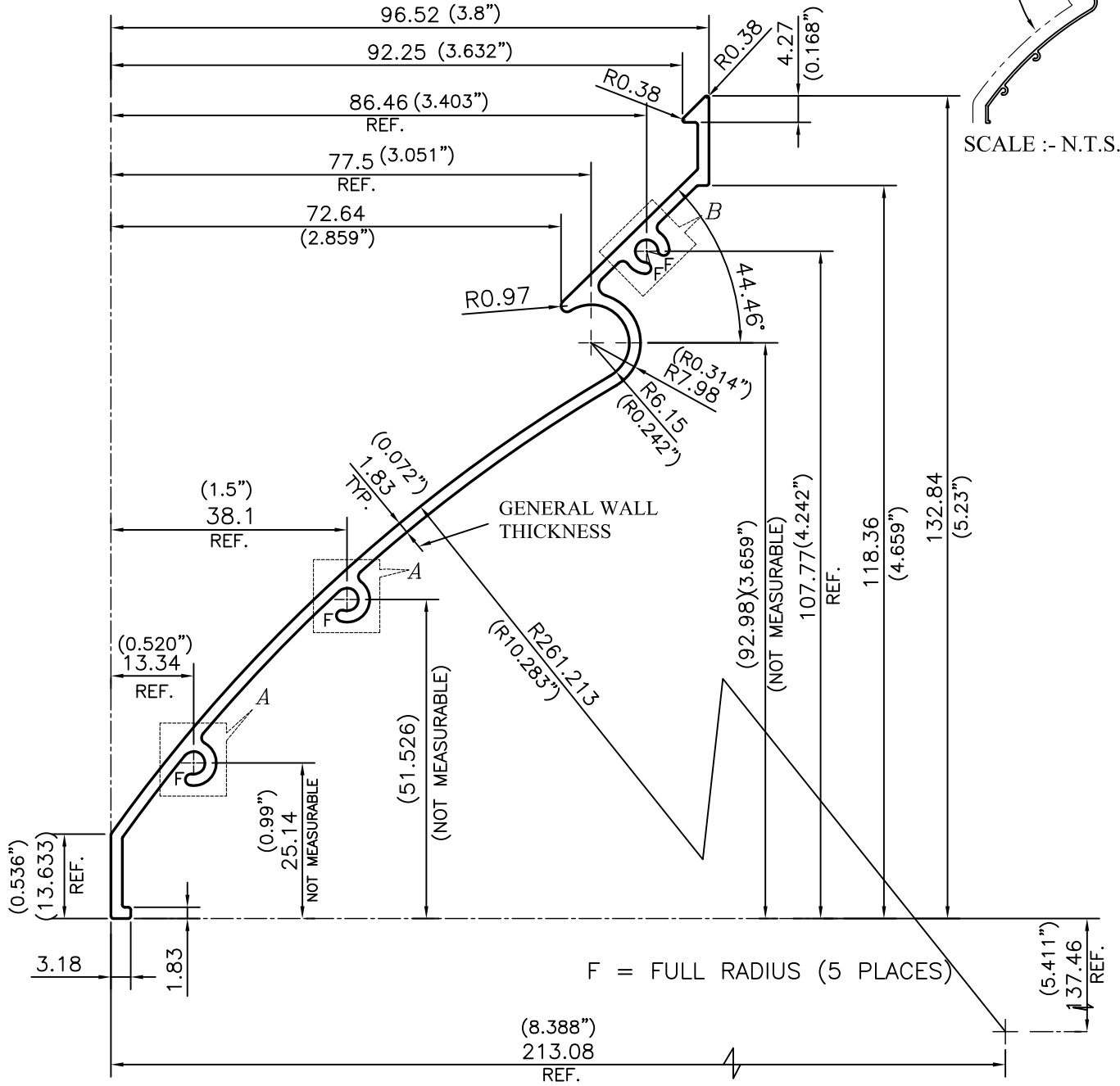
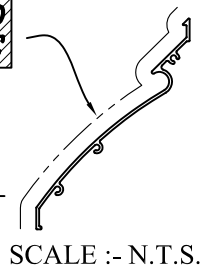

SYMBOL OF QUALITY
AN ISO 9001 COMPANY

JINDAL ALUMINIUM LTD.
BANGALORE-560073 (INDIA)

	NAME	DATE
DRAWN	PARVESH	04-07-2018
CHECKED		
APPROVED	B.NATARAJA	06-09-2018

- ALL DIMENSIONS ARE IN mm.
- ROUND OFF ALL SHARP CORNERS WITH 0.4 mm.
- TOLERANCES WILL BE AS PER BS:EN-755-9 , UNLESS OTHERWISE SPECIFIED

SCALE	1:1
AREA mm ²	407.553
PERIMETER mm.	428.619
WEIGHT kg/m	1.100

PARTY'S NAME	VENTEX INC, CANADA
PARTY'S DRAWING No.	AS-37469-1
ALLOY & TEMPER	6063 T6
DESCRIPTION	STORM LOUVRE BLADE-4"

DRAWING No.	SECTION No.
P-18287-4	-
X2359	X2359